



S



SK



B

PRODUCT DATA SHEET

SAFETY BOLT

LEGENDARY TWIN-CONE HEAVY DUTY ANCHOR
FOR HI-POWER PERFORMANCE



Legendary twin-cone heavy duty anchor for hi-power performance

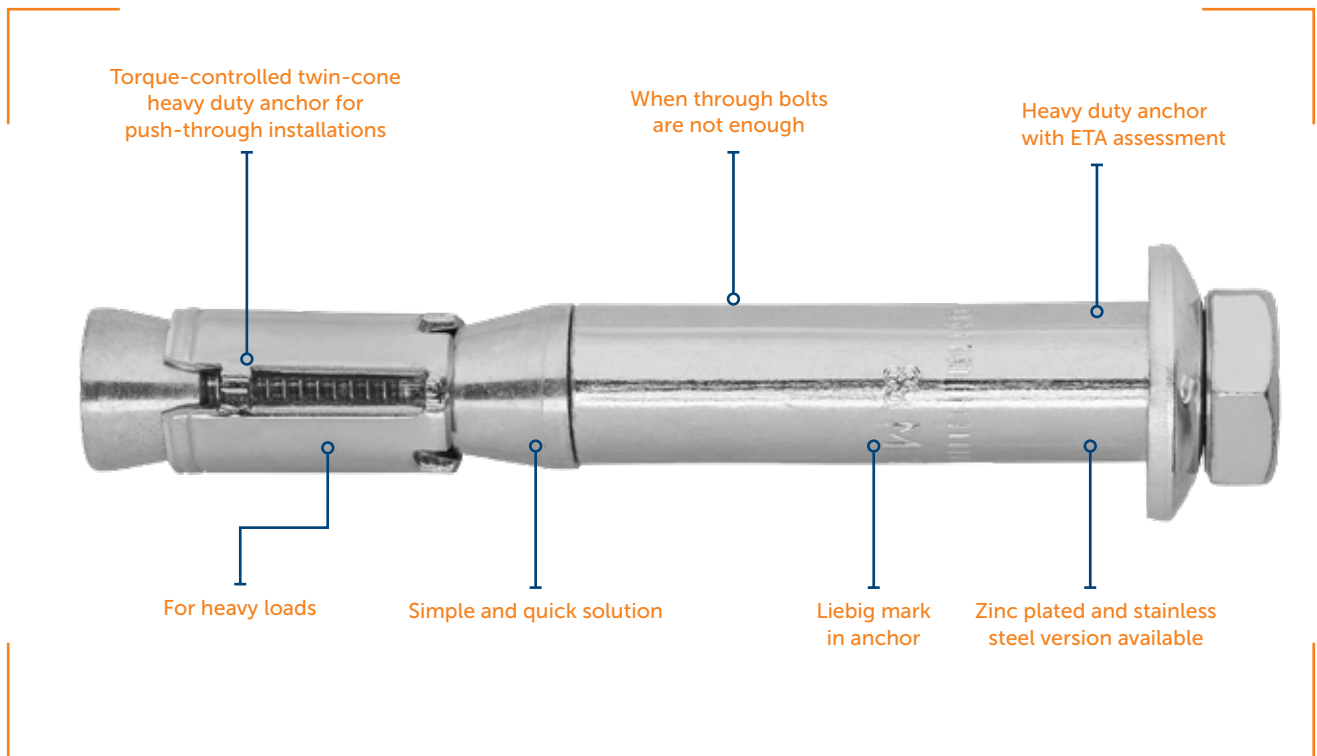

PRODUCT DESCRIPTIONS

- Torque-controlled twin-cone heavy duty anchor for push-through installations.
- Suitable for heavy loads due to optimal friction resistance.
- Cylindrical, wide expansion of sleeve over entire length.
- Equipped with domed washers providing a visual installation control.
- ZP for dry indoor and temporary outdoor use.

BASE MATERIALS

Approved for



Non-cracked concrete



Cracked concrete

Suitable for



Natural stone

VERSIONS

Type S

Push through installations
Hexagonal screw, domed washer
Zinc electropl. acc. EN ISO 4042, $t \geq 5 \mu\text{m}$



Dry indoor conditions, indoor with temporary condensation



Type SK

Push through installations
Countersunk head screw, threaded bolt, nut and domed washer



Dry indoor conditions, indoor with temporary condensation



Type B





Push through installations
Threaded bolt, nut and domed washer
Zinc electropl. acc. EN ISO 4042, $t \geq 5 \mu\text{m}$



Dry indoor conditions, indoor with temporary condensation



APPROVALS / CERTIFICATIONS / APPLICATIONS

Description of document		Authority/ Laboratory	ID	Additional info
European Technical Assessment		Deutsches Institut Für Bautechnik	ETA-06/0108 Option 1	Zinc plated M6-M16
Fire resistance		Deutsches Institut Für Bautechnik	ETA-06/0108	EOTA TR 020 - Evaluation of Anchorages in Concrete concerning Resistance to Fire
CAD-blocks for AutoCAD		Sormat Oy		Blocks installation instructions for AutoCAD
Components for TEKLA Structures		Sormat Oy		Tekla structures components + instructions video
Sormat Trustfix anchor calculation software		Sormat Oy / S&P Software Consulting		TrustFIX anchor calculation

STATIC AND QUASI-STATIC LOADS: S, B, SK

The data of these tables is based on:

- ETA-06/0108 Zinc plated anchors
- Concrete C20/25, $f_{ck,cube} = 25 \text{ N/mm}^2$
- Installation has been done correctly (p. 10)
- Without influence of edge- and spacing distances (p. 11)
- Respect of minimum base material thickness (p. 11)

Anchor size		M6	M8	M10	M12	M16
Effective anchorage depth h_{ef}	[mm]	45	55	70	80	100
Nominal anchorage depth h_{nom}	[mm]	52	63	76	92	114

Characteristic resistances

Anchor size		M6	M8	M10	M12	M16
Non-cracked concrete						
Tensile N_{Rk}	[kN]	7,5	12,0	20,0	36,1	50,5
Shear V_{Rk}	[kN]	15,0*	20,6	39,0*	60,0*	96,0*
Cracked concrete						
Tensile N_{Rk}	[kN]	6,0	9,0	16,0	25,8	36,0
Shear V_{Rk}	[kN]	10,9	14,7	39,0	51,5	72,0

* Failure mode = STEEL

Design resistances

Anchor size		M6	M8	M10	M12	M16
Non-cracked concrete						
Tensile N_{Rd}	[kN]	4,2	6,7	13,3	23,9	33,7
Shear V_{Rd}	[kN]	10,2	13,7	31,2*	48,0*	67,2
Cracked concrete						
Tensile N_{Rd}	[kN]	3,3	5,0	10,7	17,2	24,0
Shear V_{Rd}	[kN]	7,3	9,8	25,2	34,3	48,0

* Failure mode = STEEL

Recommended loads

Anchor size		M6	M8	M10	M12	M16
Non-cracked concrete						
Tensile N_{rec}	[kN]	3,0	4,8	9,5	17,1	24,0
Shear V_{rec}	[kN]	7,2	9,8	22,3*	34,3*	48,0
Cracked concrete						
Tensile N_{rec}	[kN]	2,4	3,6	7,6	12,3	17,1
Shear V_{rec}	[kN]	5,2	7,0	20,1	24,5	34,3

* Failure mode = STEEL

The partial safety factor for action is $\gamma = 1.4$.

FIRE RESISTANCE: S, B, SK

Design method acc. to EOTA TR 020

The data of these tables is based on:

- ETA-06/0108 zinc plated anchors
- Concrete C20/25, $f_{ck,cube} = 25 \text{ N/mm}^2$
- In the absence of other national regulations the partial safety factor for resistance under fire exposure $\gamma_{M,fi} = 1,0$ is recommended
- Installation has been done correctly (p. 10)
- Without influence of edge- and spacing distances (p. 11)
- Respect of minimum base material thickness (p. 11)



Characteristic resistances

Anchor size		M6	M8	M10	M12	M16
Effective anchorage depth h_{ef} [mm]		45	55	70	80	100
Non-cracked / cracked concrete						
R30	Tensile $N_{Rk,fi}$ [kN]	0,2	0,4	0,9	1,7	3,1
	Shear $V_{Rk,fi}$ [kN]	0,2	0,4	0,9	1,7	3,1
R120	Tensile $N_{Rk,fi}$ [kN]	0,1	0,2	0,5	0,8	1,6
	Shear $V_{Rk,fi}$ [kN]	0,1	0,2	0,5	0,8	1,6

Design resistances

Anchor size		M6	M8	M10	M12	M16
Effective anchorage depth h_{ef} [mm]		45	55	70	80	100
Non-cracked / cracked concrete						
R30	Tensile $N_{Rd,fi}$ [kN]	0,2	0,4	0,9	1,7	3,1
	Shear $V_{Rd,fi}$ [kN]	0,2	0,4	0,9	1,7	3,1
R120	Tensile $N_{Rd,fi}$ [kN]	0,1	0,2	0,5	0,8	1,6
	Shear $V_{Rd,fi}$ [kN]	0,1	0,2	0,5	0,8	1,6

Recommended loads

Anchor size		M6	M8	M10	M12	M16
Effective anchorage depth h_{ef} [mm]		45	55	70	80	100
Non-cracked / cracked concrete						
R30	Tensile $N_{rec,fi}$ [kN]	0,2	0,4	0,9	1,7	3,1
	Shear $V_{rec,fi}$ [kN]	0,2	0,4	0,9	1,7	3,1
R120	Tensile $N_{rec,fi}$ [kN]	0,1	0,2	0,5	0,8	1,6
	Shear $V_{rec,fi}$ [kN]	0,1	0,2	0,5	0,8	1,6

In absence of other national regulations the partial safety factor for resistance under fire exposure $\gamma_{M,fi} = 1,0$ is recommended.

MATERIALS AND DIMENSIONS

Mechanical properties: **S, B, SK**

Anchor size		M6	M8	M10	M12	M16
Nominal tensile strength F_{uk}	[N/mm ²]	800	800	800	800	800
Char. bending resistance $M_{Rk,s}^0$	[kN]	12,0	30,0	59,8	104,8	266,4
Design bending resistance $M_{Rd,s}$	[kN]	9,6	24,0	47,8	83,8	213,1
Recommended bending resistance M_{rec}	[kN]	6,9	17,1	34,2	59,9	152,2

Zinc plated: **S, B, SK**

Part		Material
1	Threaded bolt	EN ISO 898-1: grade 8.8
2	Threaded cone	Carbon steel
3	Expansion shield	Carbon steel
4	Untreaded cone	Carbon steel
5	Distance sleeve	Carbon steel
6	Domed washer	Carbon steel
7	Hexagonal nut	EN ISO 898-2: grade 8
8	Hexagonal screw	EN ISO 898-1: grade 8.8
9	Countersunk washer	EN 10025: 1.0037 / EN 10087: 1.0718
10	Countersunk screw	EN ISO 898-1: grade 8.8

All parts zinc electroplated according to EN ISO 4024 $\geq 5 \mu\text{m}$, passivated.

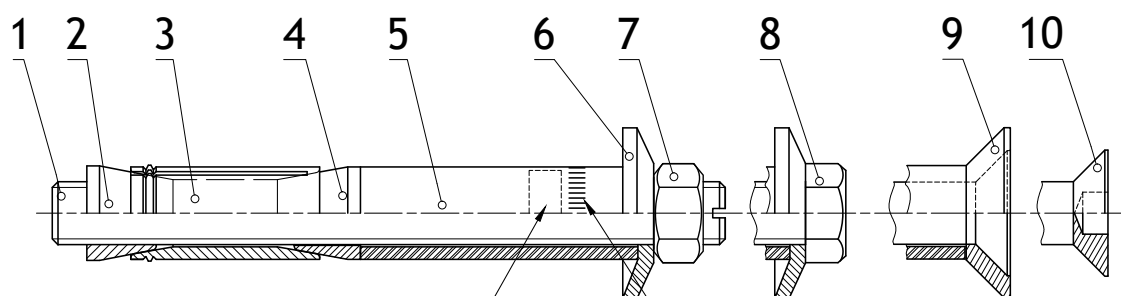

Branding

Identifying mark:

Thread size:

Max. fixture thickness

Example:



Setting depth marking: knurl

ANCHOR DIMENSIONS

Types S, B, SK

Anchor size			M6	M8	M10	M12	M16	
Nominal diameter	M	[mm]	6	8	10	12	16	
Max diameter of threaded cone	d_c	[mm]	10	12	15	19,7	24,7	
Max diameter of sleeve	d_h	[mm]	9,8	12,0	15,0	19,4	24,5	
Max diameter of washer	S, B, SK	d_w	15	20	25	30	40	
Washer/screw head	TYPE SK	S_k	[mm]	0,5	0,5	1	1	1
		k	[mm]	5,5	6,5	7	8	14
		d_k	[mm]	20	24	27	33	50

Type B (with hexagonal bolt)

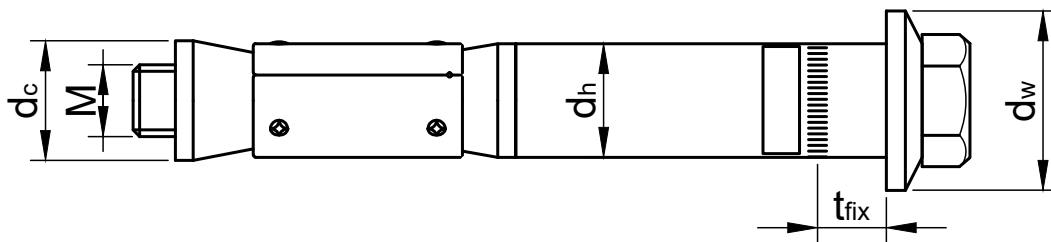

Type S (with nut)

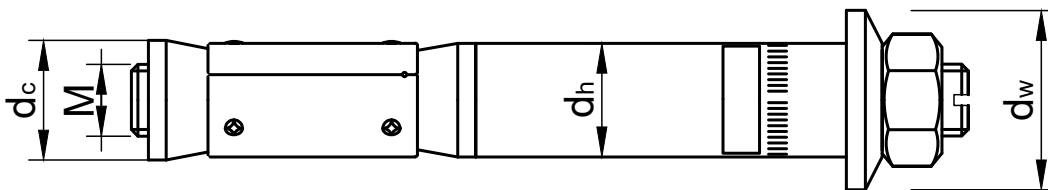

Type SK (with countersunk screw)

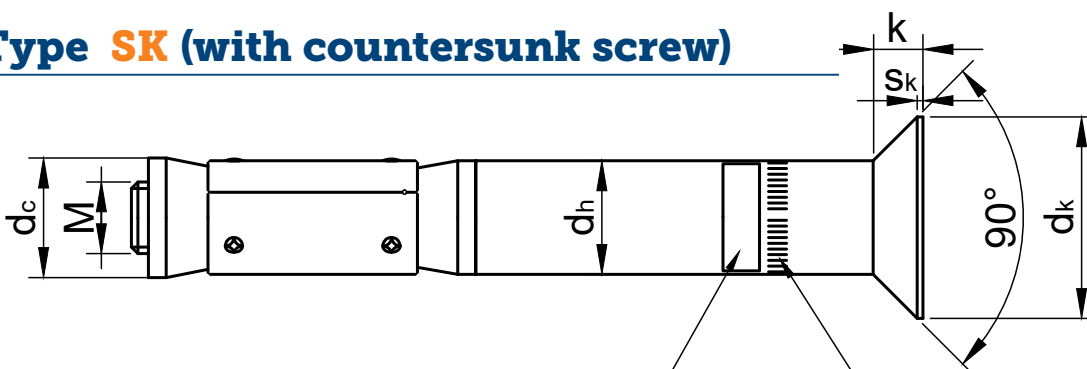

Branding: _____

Identifying mark: 

Thread size: M...

Max fixture thickness: t_{fix}

Example:

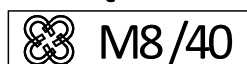

Setting depth marking: knurl

SETTING INSTRUCTIONS

Installation equipment for **S, B, SK**

Specification	M6	M8	M10	M12	M16
Drill bit	SDS+ 2-CUT or 4-CUT				
	ø 10 mm	ø 12 mm	ø 15 mm	ø 20 mm	ø 25 mm
Rotary hammer	750...1200 r.p.m / 1.8 ...3.3 J				
					360...550 r.p.m / 4,9 ...11,5 J
Additional tools	Air pump/compressor, hammer, torque wrench				

Type **S**

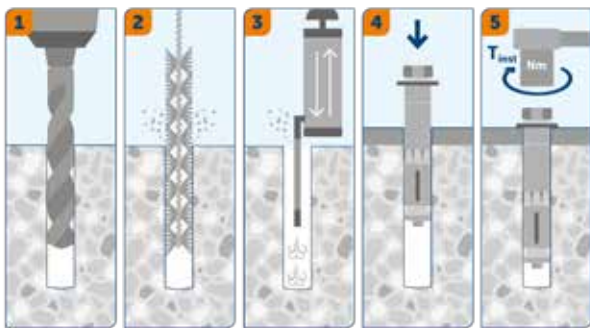

Type **B**

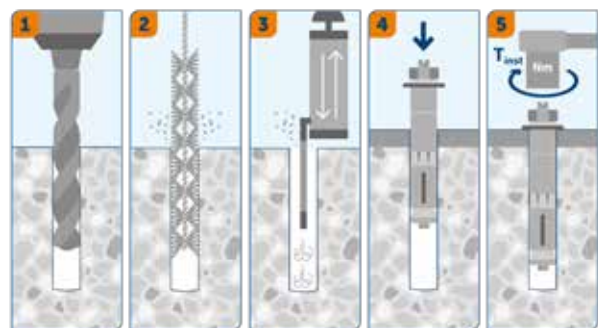

Type **SK**

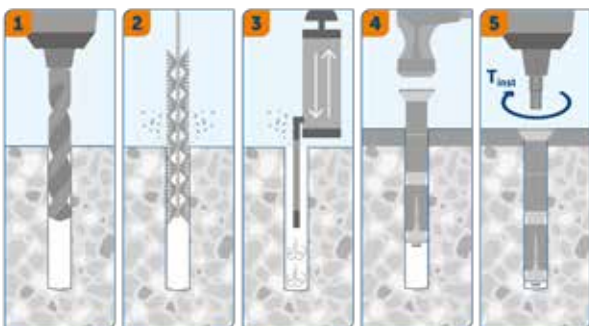

INSTALLATION DATA

Types S, B, SK

Parameters and anchors sizes			M6	M8	M10	M12	M16
Drill hole diameter	d_0	[mm]	10	12	15	20	25
Diameter of the drill bit at the upper tolerance limit	$d_{cut,max} \leq$	[mm]	10,45	12,50	15,50	20,55	25,55
Depth of drilled hole to deepest point	$h_1 \geq$	[mm]	60	70	85	100	125
Effective anchorage depth	h_{ef}	[mm]	45	55	70	80	100
Nominal anchorage depth	h_{nom}	[mm]	52	63	76	92	114
Diameter of clearance hole in the fixture	d_f	[mm]	12	14	17	21	26
Torque moment type B			8 / 10	15 / 25	40 / 50	70 / 80	115 / 180
Torque moment type S	T_{inst}	[Nm]	8 / 10	20 / 25	60 / 50	90 / 80	170 / -
Torque moment type SK			12 / 10	20 / 25	60 / 50	90 / 80	190 / -
Width across flats type S	SW	[mm]	10	13	17	19	24
Dimension of HEX-Drive SK	HEX-Drive	[mm]	4	5	6	8	10

Type S

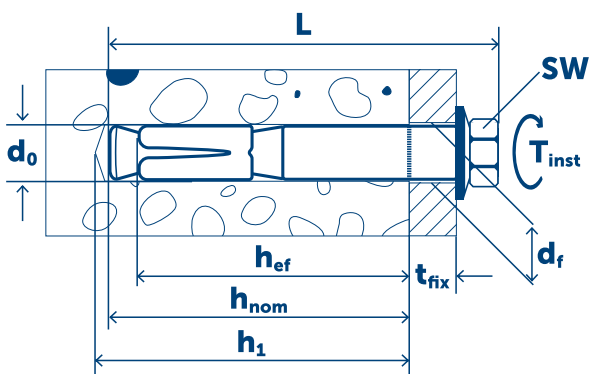

Type B

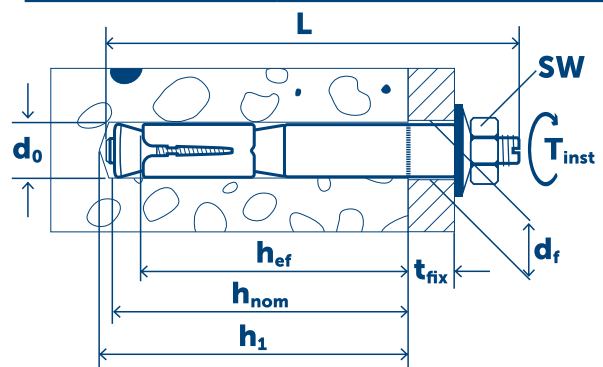

Type SK

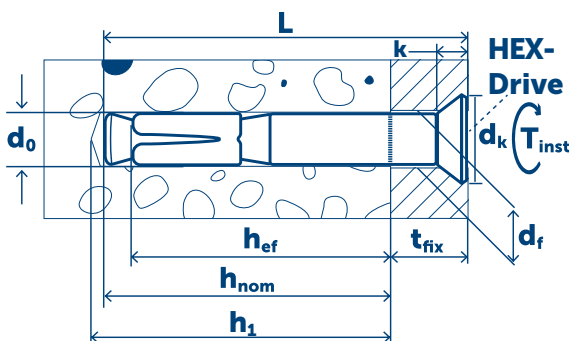

MINIMUM THICKNESS OF CONCRETE MEMBER, SPACING AND EDGE DISTANCE

Types **S, B, SK**

Cracked concrete and non-cracked concrete			M6	M8	M10	M12	M16	
Effective anchorage depth	h_{ef}	[mm]	45	55	70	80	100	
Nominal anchorage depth	h_{nom}	[mm]	52	63	76	92	114	
Minimum thickness of base material	h_{min}	[mm]	100	110	140	160	200	
Minimum spacing	s_{min}	[mm]	60	100	150	200	250	
	$c \geq$	[mm]	130	200	300	500	600	
Minimum edge distance	c_{min}	[mm]	80	100	150	200	250	
	$s \geq$	[mm]	140	200	250	380	440	
Critical spacing for splitting failure and concrete cone failure *	Center Spacing (splitting)	$s_{cr,sp}$	[mm]	225	275	350	400	500
	Center spacing	$s_{cr,N}$	[mm]	135	165	210	240	300
Critical edge distance for splitting failure and concrete cone failure *	Edge distance (splitting)	$c_{cr,sp}$	[mm]	113	138	175	200	250
	Edge distance	$c_{cr,N}$	[mm]	68	83	105	120	150

* in case characteristic loading affects

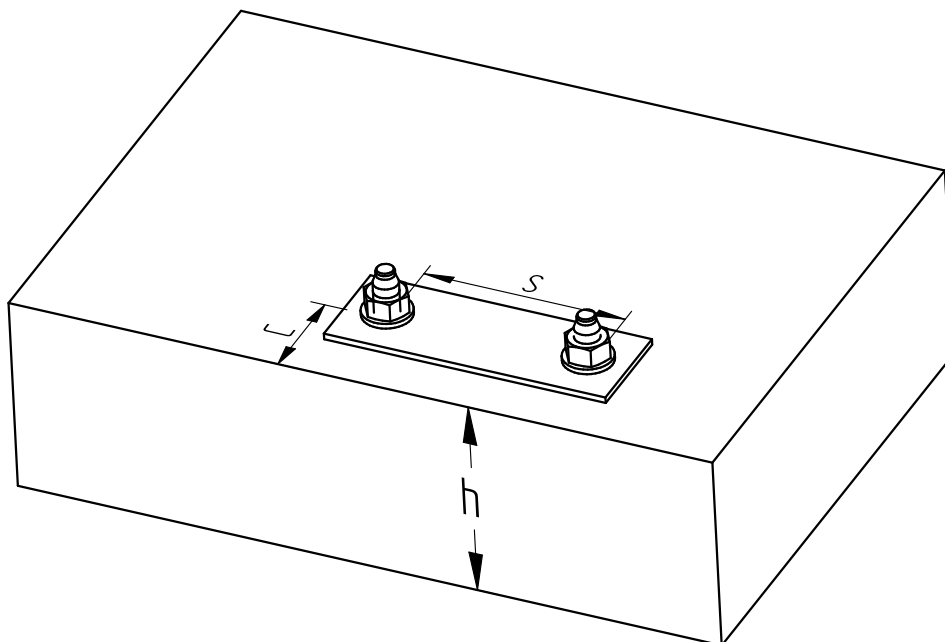

DELIVERY PROGRAM

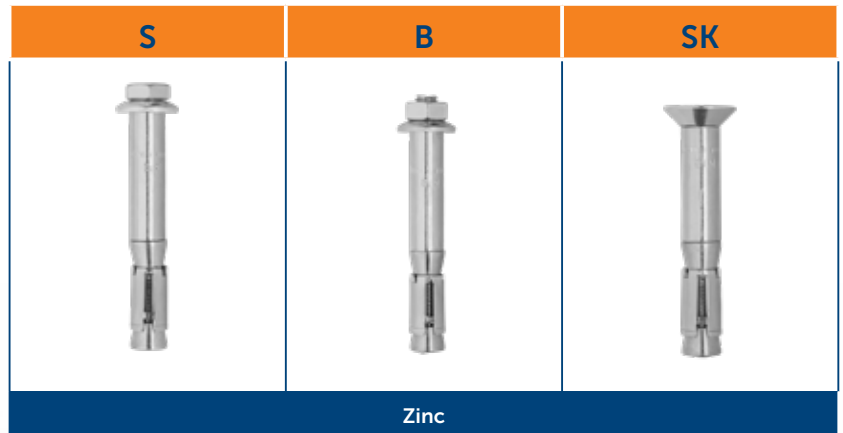

Thread size	Drill \varnothing / Anchorage depth h_{ef}	t_{fix}	t_{fix}	t_{fix}
M6	10 / 45	5	5	
		15	15	15
		40	40	40
M8	12 / 55	5	5	
		15	15	15
		40	40	40
			65	
		100		
M10	15 / 70	5	5	10
		15	15	15
		40	40	40
			65	
		100		
M12	20 / 80	5	5	
		15	15	15
		40	40	40
			65	
		100		
M16	25 / 100	5	5	
		15	15	15
		40	40	40
			65	
		100		

* No ETA