



**S-CSA+ HEX**  
SIZES 8 | 10 | 14



**S-CSA HEX**  
SIZES 5 | 6



**S-CSA CS**  
SIZES 5 | 6



**S-CSA I**  
SIZE 6



**S-CSA P**  
SIZE 6



**S-CSA HEX A4**  
SIZE 6 | 8 | 10

# CONCRETE SCREWS

## PRODUCT DATA SHEET



HEX, CS, I, P CONCRETE SCREWS

# ETA-APPROVED, HIGH PERFORMANCE CONCRETE SCREWS FROM FINLAND

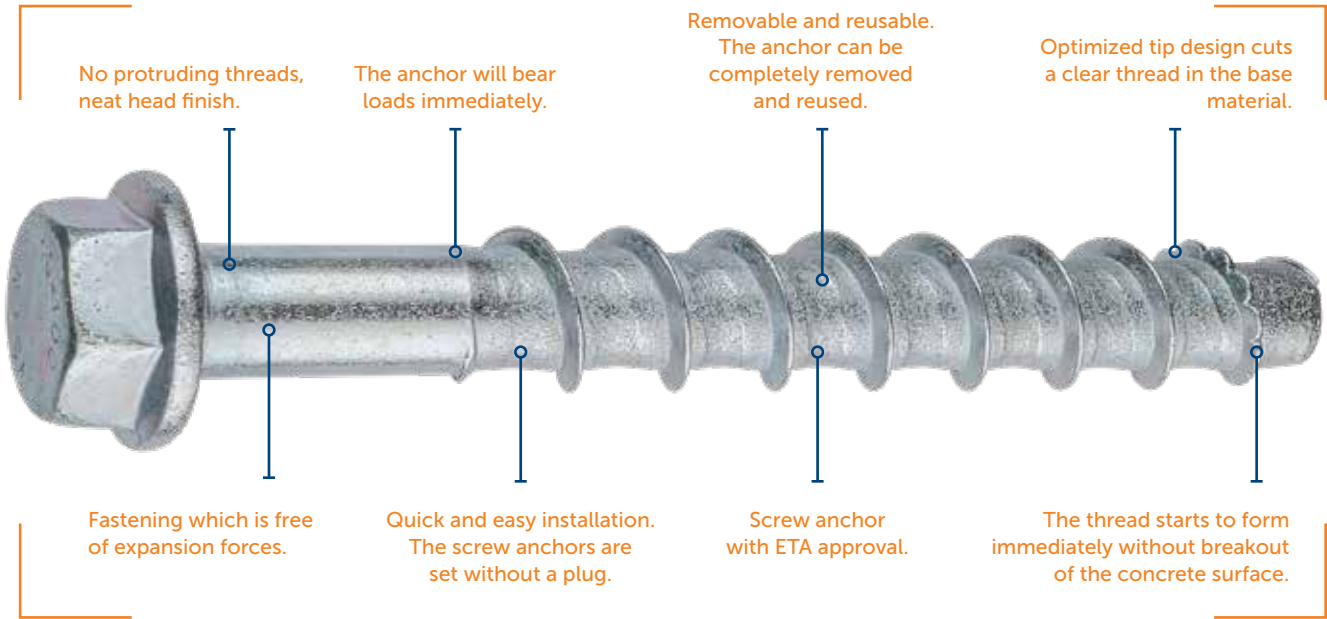

## CONCRETE SCREW S-CSA

The S-CSA and S-CSA+ concrete screws are very easy and quick to install. Requires neither additional tools nor operations. It is able to take high loads even with relatively small spacings and edge distances. It is removable and reusable and therefore fits also well for temporary fixings.

### Description

- Self-tapping, approved screw anchors for push-through installations.
- No expansion forces allowing for relatively small edge distances and spacings.
- ZP (zinc electro plated) for dry indoor use.
- ML (Multi Layer coated) corrosion resistant coating. S-CSA ML has been neutral salt spray tested according to DIN EN ISO 9227 (prevention of red rust for more than 1000 h)
- A4 Stainless Steel with hardened carbon steel tip, coated
- Combines the benefits of undercut and chemical anchors requiring neither additional tools and operations nor hardening time.

- S-CSA(+) HEX: hexagon head with flange
- S-CSA+ HEX WOF: hexagon head without flange
- S-CSA I: combined internal thread M8/M10
- S-CSA CS: countersunk head
- S-CSA P: pan head
- S-CSA P(L): low pan head
- S-CSA HEX A4

• The concrete screw is installed directly through the fixture into the bore hole only by screwing. By doing so, the thread is cutting itself into the concrete and that way creating a mechanical interlock over the total anchorage depth.

### Benefits

- Economic installation
- Quick and easy installation
- No expansion forces
- Relatively small spacings and edge distances possible
- Removable
- Can be reused



HEX, CS, I, P CONCRETE SCREWS

# TYPES

## S-CSA+ HEX

Concrete screw with hexagonal head and flange. Sizes 8, 10, 14



## S-CSA+ HEX WOF

Concrete screw with hexagonal head without flange. Size 14



## S-CSA HEX

Concrete screw with hexagonal head and flange. Sizes 5, 6  
Size 6 has also T-drive



## S-CSA CS

Concrete screw with countersunk head and T-drive. Sizes 5, 6

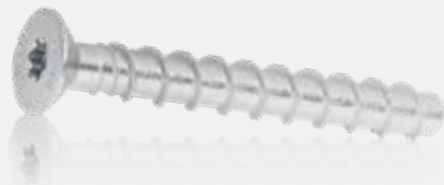

## S-CSA I

Concrete screw with combined internal thread M8 / M10. Size 6



## S-CSA P

Concrete screw with pan head and T-drive. Size 6

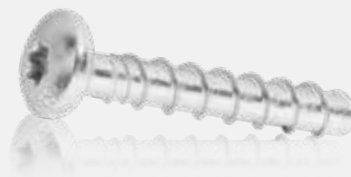

## S-CSA HEX A4

Concrete screw with hexagonal head and flange. Size 6,8 and 10



## BASE MATERIALS

Approved for



Cracked concrete



Non-cracked concrete



Hollow concrete slab

Also suitable for













Solid clay brick



Solid sand-lime brick

## APPROVALS / CERTIFICATIONS / APPLICATIONS

| Description of document  | Authority/ Laboratory  | ID   | Additional info  |
|--|--|--|--|
| European Technical Assessment<br>                 | ZAG -National Building and Civil Engineering Institute, Slovenia | ETA-16/0945 (S-CSA 6)                                    | EAD 330232-01-0601, Option 1   |
| European Technical Assessment<br>                 | ZAG -National Building and Civil Engineering Institute, Slovenia | ETA-17/1009 (S-CSA 6)                                    | Concrete screw of size 6 for multiple use in non-structural applications, EAD 330747-00-0601, (Part 6) |
| European Technical Assessment<br>                 | ZAG -National Building and Civil Engineering Institute, Slovenia | ETA-20/0446 (S-CSA+ 8, 10, 14)                           | EAD 330232-01-0601, Option 1   |
| European Technical Assessment<br>                 | ZAG -National Building and Civil Engineering Institute, Slovenia | ETA-22/0413 (S-CSA A4)                                   | EAD 330232-01-0601, Option 1   |
| General construction technique permit DIBt<br>    | DIBt   | Z-21.8-2136  | S-CSA+ 14 mm for temporary fastenings in concrete  |
| Seismic resistance<br>                            | ZAG -National Building and Civil Engineering Institute, Slovenia | ETA-20/0446 (S-CSA+ 8, 10, 14)                           | EN 1992-4  |
| Fire resistance<br>                              | ZAG -National Building and Civil Engineering Institute, Slovenia | ETA-16/0945<br>ETA-17/1009<br>ETA-20/0446<br>ETA-22/0413 |  |
| YouTube installation videos<br>                 | EJOT Sormat Oy   | Fnr5QcrK-q0  | Sormat S-CSA Concrete screw installation video   |
| Sormat Trustfix anchor calculation software<br> | Sormat Oy / S&P Software Consulting                              |  | TrustFIX anchor calculation  |
| CAD-blocks for AutoCAD<br>                      | EJOT Sormat Oy   |  | Blocks installation instructions for AutoCAD   |
| ProdLib<br>                                     | ProdLib Oy   | prodlib.com/library/sormat                               | CAD block library  |

### Additional information concerning all given data in the product data sheet

- Load figures include the partial safety factors as per approvals and a partial safety factor on the action of  $\gamma_F = 1.4$ . Load figures apply for a rebar spacing  $s \geq 15$  cm or alternatively for a rebar spacing  $s \geq 10$  cm in combination with a rebar diameter of  $d_s \leq 10$  mm.
- If spacings or edge distances become smaller than the characteristic figures ( $s_{Cr,N} / c_{Cr,N}$ ) a calculation as per EN 1992-4 needs to be carried out. For more details, see ETA-16/0945, ETA-17/1009, ETA-20/0446 and ETA-22/0413.
- Concrete is considered non-cracked when the value of tension within the concrete is  $\sigma_L + \sigma_R \leq 0$ . In the absence of detailed verification  $\sigma_R = 3$  N/mm<sup>2</sup> can be assumed ( $\sigma_L$  equals the tension within the concrete as a result of external loads, forces on anchor included;  $\sigma_R$  equals the tension coming from shrinkage or creep of the concrete, as well as displacements of supports or temperature variations).
- Shear load figures apply for an anchor without influence of a concrete edge. For shear loads close to an edge ( $c \leq 10 \times h_{ef}$ ), concrete edge failure has to be checked as per EN 1992-4.

# STATIC AND QUASI-STATIC LOADS S-CSA / S-CSA+

The data of these tables is based on:

- Concrete C20/25,  $f_{ck,cube} = 25 \text{ N/mm}^2$ .
- Installation has been done correctly (see p. 15).
- No influence of edge distances and spacings (see p. 16).
- Respect of minimum base material thickness (see p. 16).

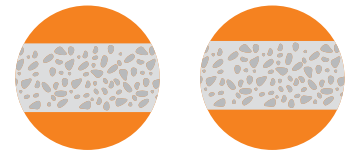

## Characteristic resistances

|                                    |      | S-CSA 5 |      | S-CSA 6 |        |       | S-CSA+ 8 |       | S-CSA+ 10 |       | S-CSA+ 14 |       |
|------------------------------------|------|---------|------|---------|--------|-------|----------|-------|-----------|-------|-----------|-------|
|                                    |      | -       | -    | PART 6  | PART 6 | OPT 1 | OPT 1    | OPT 1 | OPT 1     | OPT 1 | OPT 1     | OPT 1 |
| Effective anchorage depth $h_{ef}$ | [mm] | 19,0    | 27,5 | 27,6    | 31,9   | 42,5  | 39,2     | 51,9  | 42,5      | 68,0  | 49,3      | 91,8  |
| Nominal anchorage depth $h_{nom}$  | [mm] | 35      | 45   | 35      | 40     | 55    | 50       | 65    | 55        | 85    | 65        | 115   |
| <b>Non-cracked concrete</b>        |      |         |      |         |        |       |          |       |           |       |           |       |
| Tension $N_{Rk}$                   | [kN] | 2,4     | 3,5  | 3,0     | 3,5    | 9,5   | 12,1     | 18,4  | 13,6      | 27,6  | 15,0      | 42,0  |
| Shear $V_{Rk}$                     | [kN] | 2,4     | 3,5  | 9,4*    | 9,4*   | 9,8*  | 19,1*    | 21,5* | 31,8*     | 35,2* | 56,2      | 64,9* |
| <b>Cracked concrete</b>            |      |         |      |         |        |       |          |       |           |       |           |       |
| Tension $N_{Rk}$                   | [kN] | NA      | NA   | 3,0     | 3,5    | 4,5   | 6,5      | 12,0  | 7,5       | 19,0  | 8,5       | 30,0  |
| Shear $V_{Rk}$                     | [kN] | NA      | NA   | 9,4*    | 9,4*   | 9,5   | 19,1*    | 21,5* | 28,6      | 35,2* | 39,3      | 64,9* |

\* Failure mode = steel

## Design resistances

|                                    |      | S-CSA 5 |      | S-CSA 6 |        |       | S-CSA+ 8 |       | S-CSA+ 10 |       | S-CSA+ 14 |       |
|------------------------------------|------|---------|------|---------|--------|-------|----------|-------|-----------|-------|-----------|-------|
|                                    |      | -       | -    | PART 6  | PART 6 | OPT 1 | OPT 1    | OPT 1 | OPT 1     | OPT 1 | OPT 1     | OPT 1 |
| Effective anchorage depth $h_{ef}$ | [mm] | 19,0    | 27,5 | 27,6    | 31,9   | 42,5  | 39,2     | 51,9  | 42,5      | 68,0  | 49,3      | 91,8  |
| Nominal anchorage depth $h_{nom}$  | [mm] | 35      | 45   | 35      | 40     | 55    | 50       | 65    | 55        | 85    | 65        | 115   |
| <b>Non-cracked concrete</b>        |      |         |      |         |        |       |          |       |           |       |           |       |
| Tension $N_{Rd}$                   | [kN] | 1,6     | 2,3  | 2,0     | 2,3    | 6,3   | 8,0      | 12,3  | 9,1       | 18,4  | 10,0      | 28,0  |
| Shear $V_{Rd}$                     | [kN] | 1,6     | 2,3  | 7,5*    | 7,5*   | 7,8*  | 15,3*    | 17,2* | 25,4*     | 28,2* | 37,5      | 51,9* |
| <b>Cracked concrete</b>            |      |         |      |         |        |       |          |       |           |       |           |       |
| Tension $N_{Rd}$                   | [kN] | NA      | NA   | 2,0     | 2,3    | 3,0   | 4,3      | 8,0   | 5,0       | 12,7  | 5,7       | 20,0  |
| Shear $V_{Rd}$                     | [kN] | NA      | NA   | 7,5*    | 7,5*   | 6,3   | 15,3*    | 17,2* | 19,1      | 28,2* | 26,2      | 51,9* |

\* Failure mode = steel

## Recommended loads

|                                    |      | S-CSA 5 |      | S-CSA 6 |        |       | S-CSA+ 8 |       | S-CSA+ 10 |       | S-CSA+ 14 |       |
|------------------------------------|------|---------|------|---------|--------|-------|----------|-------|-----------|-------|-----------|-------|
|                                    |      | -       | -    | PART 6  | PART 6 | OPT 1 | OPT 1    | OPT 1 | OPT 1     | OPT 1 | OPT 1     | OPT 1 |
| Effective anchorage depth $h_{ef}$ | [mm] | 19,0    | 27,5 | 27,6    | 31,9   | 42,5  | 39,2     | 51,9  | 42,5      | 68,0  | 49,3      | 91,8  |
| Nominal anchorage depth $h_{nom}$  | [mm] | 35      | 45   | 35      | 40     | 55    | 50       | 65    | 55        | 85    | 65        | 115   |
| <b>Non-cracked concrete</b>        |      |         |      |         |        |       |          |       |           |       |           |       |
| Tension $N_{Rec}$                  | [kN] | 1,1     | 1,7  | 1,4     | 1,7    | 4,5   | 5,7      | 8,8   | 6,5       | 13,1  | 7,1       | 20,0  |
| Shear $V_{Rec}$                    | [kN] | 1,1     | 1,7  | 5,4*    | 5,4*   | 5,6*  | 10,9*    | 12,3* | 18,2*     | 20,1* | 26,8      | 37,1* |
| <b>Cracked concrete</b>            |      |         |      |         |        |       |          |       |           |       |           |       |
| Tension $N_{Rec}$                  | [kN] | NA      | NA   | 1,4     | 1,7    | 2,1   | 3,1      | 5,7   | 3,6       | 9,0   | 4,0       | 14,3  |
| Shear $V_{Rec}$                    | [kN] | NA      | NA   | 5,4*    | 5,4*   | 4,5   | 10,9*    | 12,3* | 13,6      | 20,1* | 18,7      | 37,1* |

\* Failure mode = steel

The partial safety factor for action is  $\gamma = 1.4$ .

## STATIC AND QUASI-STATIC LOADS S-CSA A4

The data of these tables is based on:

- Concrete C20/25,  $f_{ck,cube} = 25 \text{ N/mm}^2$ .
- Installation has been done correctly (see p. 17).
- No influence of edge distances and spacings (see p. 17).
- Respect of minimum base material thickness (see p. 17).

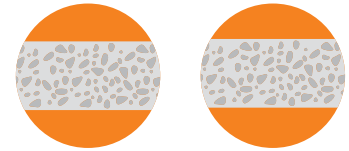

### Characteristic resistances

|                                    |                  |      | S-CSA A4 6 |       | S-CSA A4 8 |       | S-CSA A4 10 |       |
|------------------------------------|------------------|------|------------|-------|------------|-------|-------------|-------|
|                                    |                  |      | OPT 1      |       | OPT 1      |       | OPT 1       |       |
| Effective anchorage depth $h_{ef}$ | [mm]             |      | 34,0       | 42,5  | 35,8       | 48,5  | 39,1        | 64,6  |
| Nominal anchorage depth $h_{nom}$  | [mm]             |      | 45         | 55    | 50         | 65    | 55          | 85    |
| <b>Non-cracked concrete</b>        | Tension $N_{Rk}$ | [kN] | 6,0        | 9,5   | 8,5        | 16,6  | 11,0        | 25,4  |
|                                    | Shear $V_{Rk}$   | [kN] | 14,3*      | 14,3* | 24,3*      | 24,3* | 29,4*       | 29,4* |
| <b>Cracked concrete</b>            | Tension $N_{Rk}$ | [kN] | 2,5        | 3,5   | 3,0        | 8,5   | 2,5         | 9,0   |
|                                    | Shear $V_{Rk}$   | [kN] | 14,3*      | 14,3* | 24,3*      | 24,3* | 29,4*       | 29,4* |

\* Failure mode = steel

### Design resistances

|                                    |                  |      | S-CSA A4 6 |      | S-CSA A4 8 |       | S-CSA A4 10 |       |
|------------------------------------|------------------|------|------------|------|------------|-------|-------------|-------|
|                                    |                  |      | OPT 1      |      | OPT 1      |       | OPT 1       |       |
| Effective anchorage depth $h_{ef}$ | [mm]             |      | 34,0       | 42,5 | 35,8       | 48,5  | 39,1        | 64,6  |
| Nominal anchorage depth $h_{nom}$  | [mm]             |      | 45         | 55   | 50         | 65    | 55          | 85    |
| <b>Non-cracked concrete</b>        | Tension $N_{Rd}$ | [kN] | 34,0       | 42,5 | 35,8       | 48,5  | 39,1        | 64,6  |
|                                    | Shear $V_{Rd}$   | [kN] | 9,5*       | 9,5* | 16,2*      | 16,2* | 19,6*       | 19,6* |
| <b>Cracked concrete</b>            | Tension $N_{Rd}$ | [kN] | 1,7        | 2,3  | 2,0        | 5,7   | 1,7         | 6,0   |
|                                    | Shear $V_{Rd}$   | [kN] | 9,5*       | 9,5* | 14,3       | 16,2* | 18,5        | 19,6  |

\* Failure mode = steel

### Recommended loads

|                                    |                   |      | S-CSA A4 6 |      | S-CSA A4 8 |       | S-CSA A4 10 |       |
|------------------------------------|-------------------|------|------------|------|------------|-------|-------------|-------|
|                                    |                   |      | OPT 1      |      | OPT 1      |       | OPT 1       |       |
| Effective anchorage depth $h_{ef}$ | [mm]              |      | 34,0       | 42,5 | 35,8       | 48,5  | 39,1        | 64,6  |
| Nominal anchorage depth $h_{nom}$  | [mm]              |      | 45         | 55   | 50         | 65    | 55          | 85    |
| <b>Non-cracked concrete</b>        |                   |      |            |      |            |       |             |       |
| <b>Non-cracked concrete</b>        | Tension $N_{Rec}$ | [kN] | 2,9        | 4,5  | 4,0        | 7,9   | 5,2         | 12,1  |
|                                    | Shear $V_{Rec}$   | [kN] | 6,8*       | 6,8* | 11,6*      | 11,6* | 14,0*       | 14,0* |
| <b>Cracked concrete</b>            |                   |      |            |      |            |       |             |       |
| <b>Cracked concrete</b>            | Tension $N_{Rec}$ | [kN] | 1,2        | 1,7  | 1,4        | 4,0   | 1,2         | 4,3   |
|                                    | Shear $V_{Rec}$   | [kN] | 6,8*       | 6,8* | 10,2       | 11,6* | 13,2        | 14,0* |

\* Failure mode = steel

The partial safety factor for action is  $\gamma = 1.4$ .

# BASIC LOADING DATA FOR PRECAST PRE-STRESSED HOLLOW CORE SLABS

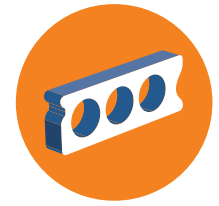

The data of these tables is based on:

- Concrete C30/37 to C50/60
- Installation has been done correctly (see page 17).
- Edge distances and spacings acc. page 17.
- The data of these tables is based on ETA-17/1009 (S-CSA 6).

## Characteristic resistances

|                          |                    |      | S-CSA 6   |           |           |
|--------------------------|--------------------|------|-----------|-----------|-----------|
| Nominal anchorage depth  | $h_{nom}$          | [mm] | 35 / 40   |           |           |
| Flange thickness         | $d_b$              | [mm] | $\geq 25$ | $\geq 30$ | $\geq 40$ |
| Load for all directions  | $F_{Rk}$           | [kN] | 2,5       | 3,5       | 5,0       |
| Char. bending resistance | $M^0_{Rk,s}$       | [Nm] | 16,0      |           |           |
| Edge distance            | $c_{cr} = c_{min}$ | [mm] | 100       |           |           |
| Spacing                  | $s_{cr} = s_{min}$ | [mm] | 100       |           |           |

## Design resistances

|                           |                    |      | S-CSA 6   |           |           |
|---------------------------|--------------------|------|-----------|-----------|-----------|
| Nominal anchorage depth   | $h_{nom}$          | [mm] | 35 / 40   |           |           |
| Flange thickness          | $d_b$              | [mm] | $\geq 25$ | $\geq 30$ | $\geq 40$ |
| Load for all directions   | $F_{Rd}$           | [kN] | 1,7       | 2,3       | 3,3       |
| Design bending resistance | $M_{Rd,s}$         | [Nm] | 12,8      |           |           |
| Edge distance             | $c_{cr} = c_{min}$ | [mm] | 100       |           |           |
| Spacing                   | $s_{cr} = s_{min}$ | [mm] | 100       |           |           |

## Recommended loads

|                         |                    |      | S-CSA 6   |           |           |
|-------------------------|--------------------|------|-----------|-----------|-----------|
| Nominal anchorage depth | $h_{nom}$          | [mm] | 35 / 40   |           |           |
| Flange thickness        | $d_b$              | [mm] | $\geq 25$ | $\geq 30$ | $\geq 40$ |
| Load for all directions | $F_{rec}$          | [kN] | 1,2       | 1,7       | 2,4       |
| Rec. bending load       | $M_{rec}$          | [Nm] | 9,1       |           |           |
| Edge distance           | $c_{cr} = c_{min}$ | [mm] | 100       |           |           |
| Spacing                 | $s_{cr} = s_{min}$ | [mm] | 100       |           |           |

The partial safety factor for action is  $\gamma = 1.4$ .

## Requirements for multiple anchoring

The definition of redundant fastening according to Member States is given in the EAD 330747 § 1.2.1. In Absence of definition by Member State the following default values may be taken.

| Minimum number of fixing points | Minimum number of anchors per fixing point | Maximum design load of action $N_{Sd}$ per fixing point |
|---------------------------------|--|---|
| <b>3</b>                        | <b>1</b>                                   | <b>2 kN</b>   |
| <b>4</b>                        | <b>1</b>                                   | <b>3 kN</b>   |

The value  $N_{Sd}$  might be increased if in the design it is shown that the requirements on the strength and stiffness of the fixture in the serviceability and ultimate states after the failure of one anchor are fulfilled.

## INSTALLATION INSTRUCTIONS IN PRE-STRESSED HOLLOW CORE SLABS

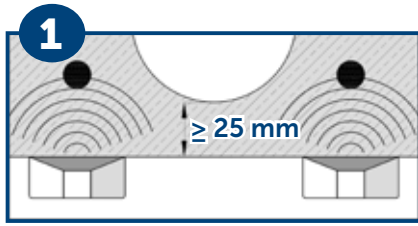

1. Locate rebars by means of suitable detector

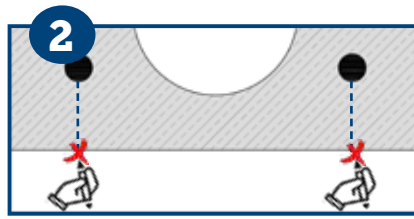

2. Mark rebar location

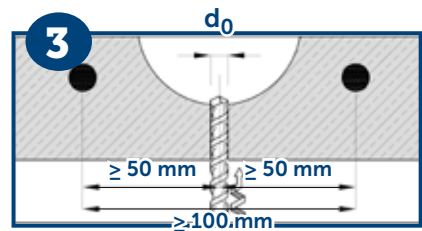

3. Make a cylindrical hole

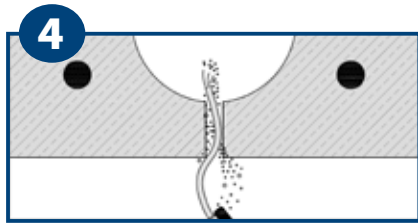

4. Clean the hole

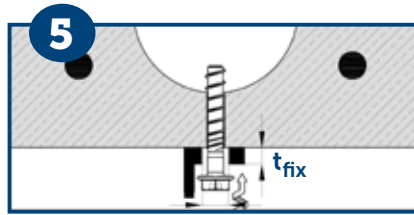

5. Install the screw anchor very gently by screwdriver or torque wrench. Avoid overtightening.

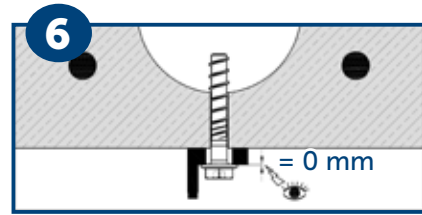

6. Ensure that the screw anchor head fully rests without any gap on the fixture and is not damaged

### Admissible anchor position in pre-stressed hollow core slabs

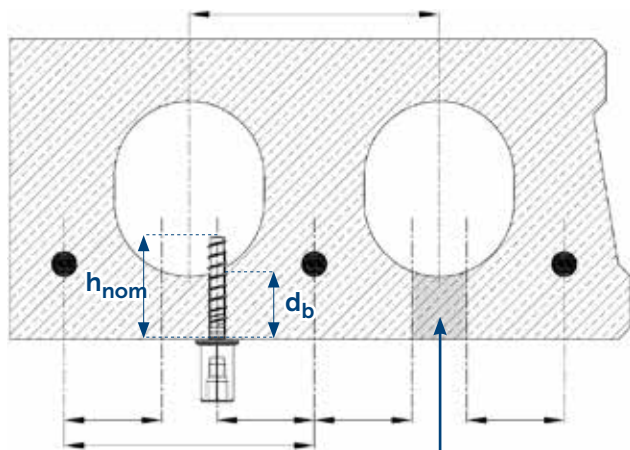

o Admissible anchor position

|   |                           |
|---|---------------------------|
| Core distance   | $l_c \geq 100 \text{ mm}$ |
| Pre-stressing steel distance                            | $l_p \geq 100 \text{ mm}$ |
| Distance between anchor position and prestressing steel | $a_p \geq 50 \text{ mm}$  |

### Minimum spacing and edge distance of anchors and distance between anchor groups in pre-stressed hollow core slabs



|  |                               |
|--|-------------------------------|
| Minimum edge distance                  | $c_{min} \geq 100 \text{ mm}$ |
| Minimum anchor spacing                 | $s_{min} \geq 100 \text{ mm}$ |
| Minimum distance between anchor groups | $a_{min} \geq 100 \text{ mm}$ |

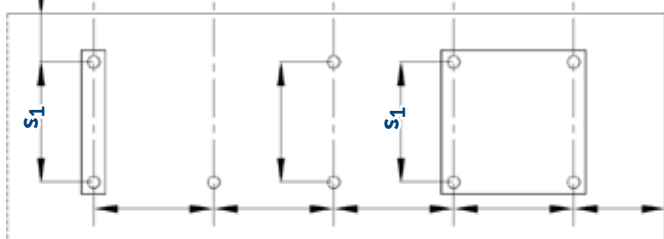

|        |                                |
|--------|--------------------------------|
| c1, c2 | edge distance                  |
| s1, s2 | anchor spacing                 |
| a1, a2 | distance between anchor groups |



## SEISMIC RESISTANCE

### Design acc. EN 1992-4 Performance category C2

The data of these tables is based on:

- Concrete C20/25,  $f_{ck,cube} = 25 \text{ N/mm}^2$
- Installation has been done correctly
- No influence of edge distances and spacings
- Respect of minimum base material thickness
- $\alpha_{gap} = 1,0$  (used with seismic filling washer, concerns only the shear values)
- ETA-20/0446 (S-CSA+)



### Characteristic resistances

| Anchor size                        |      | 8-2          | 10-2         | 14-2         |
|------------------------------------|------|--------------|--------------|--------------|
| Effective anchorage depth $h_{ef}$ | [mm] | <b>51,9</b>  | <b>68,0</b>  | <b>91,8</b>  |
| <b>Cracked concrete</b>            |      |              |              |              |
| Tension $N_{Rk, seis}$             | [kN] | <b>1,9</b>   | <b>3,8</b>   | <b>6,9</b>   |
| Shear $V_{Rk, seis}$               | [kN] | <b>13,6*</b> | <b>24,6*</b> | <b>41,5*</b> |

### Design resistances

| Anchor size                        |      | 8-2          | 10-2         | 14-2         |
|------------------------------------|------|--------------|--------------|--------------|
| Effective anchorage depth $h_{ef}$ | [mm] | <b>51,9</b>  | <b>68,0</b>  | <b>91,8</b>  |
| <b>Cracked concrete</b>            |      |              |              |              |
| Tension $N_{Rd, seis}$             | [kN] | <b>1,3</b>   | <b>2,5</b>   | <b>4,6</b>   |
| Shear $V_{Rd, seis}$               | [kN] | <b>10,9*</b> | <b>19,7*</b> | <b>33,2*</b> |

### Recommended loads

| Anchor size                        |      | 8-2         | 10-2         | 14-2         |
|------------------------------------|------|-------------|--------------|--------------|
| Effective anchorage depth $h_{ef}$ | [mm] | <b>51,9</b> | <b>68,0</b>  | <b>91,8</b>  |
| <b>Cracked concrete</b>            |      |             |              |              |
| Tension $N_{Rec, seis}$            | [kN] | <b>0,9</b>  | <b>1,8</b>   | <b>3,3</b>   |
| Shear $V_{Rec, seis}$              | [kN] | <b>7,8*</b> | <b>14,1*</b> | <b>23,7*</b> |

$\alpha_{seis}$  and  $\alpha_{gap}$  included as per EN 1992-4. The shear values consider filling of the annular gap between the anchor and the fixture.

\* Failure mode = steel

## FILLING WASHER

**For seismic applications**  
**Installation with S-CSA+ concrete screw**



When selecting a S-CSA+ concrete screw, please note that the use of the Filling Washer reduces the fixture thickness  $t_{fix}$  of the concrete screw

HEX, CS, I, P CONCRETE SCREWS



1.

1. Mount matching Filling Washer additionally to Concrete Screw



2.

2. Drive in Concrete Screw with Filling Washer until the anchorage depth  $h_{nom}$  is reached



3.

3. Stick mixer reducer tip on static mixer nozzle.  
 Adhesive tape can be used if necessary.



4.

4. Fill the annular gap between Concrete screw and fixture through the hole of the Filling Washer until resin leaks out of this hole.

Please observe installation instructions of injection resin. Load may only be applied after the curing time of the injection resin is reached.

Filling Washer is used for filling the gap between fixture and concrete screw after it has been set.

After installation, the Sormat ITH resin is injected using the mixer reducer tip (included) until resin seeps out.

| S-CSA+ concrete screw                    | 8                | 10               | 14               |
|--|------------------|------------------|------------------|
| Filling washer size                      | 26x12x5          | 28x14x5          | 34x17x5          |
| Reduction of fixture thickness $t_{fix}$ | $t_{fix} - 5$ mm | $t_{fix} - 5$ mm | $t_{fix} - 5$ mm |

# FIRE RESISTANCE S-CSA/S-CSA+

Design under fire exposure is performed according to the design method given in EN 1992-4.

The data of these tables is based on: ETA-16/0945, ETA-17/1009 and ETA-20/0446

- Concrete C20/25,  $f_{ck,cube} = 25 \text{ N/mm}^2$
- Values cannot be used with hollow core slabs
- Installation has been done correctly (p.15)
- No influence of edge distances and spacings (p. 16)
- Respect of minimum base material thickness (p. 16)



## Characteristic resistances, S-CSA/S-CSA+

|                                    |                           | S-CSA 6 |        |       | S-CSA+ 8 |      | S-CSA+ 10 |      | S-CSA+ 14 |      |
|------------------------------------|---------------------------|---------|--------|-------|----------|------|-----------|------|-----------|------|
|                                    |                           | PART 6  | PART 6 | OPT 1 | OPT 1    |      | OPT 1     |      | OPT 1     |      |
| Effective anchorage depth $h_{ef}$ | [mm]                      | 27,6    | 31,9   | 42,5  | 39,2     | 51,9 | 42,5      | 68,0 | 49,3      | 91,8 |
| Nominal anchorage depth $h_{nom}$  | [mm]                      | 35      | 40     | 55    | 50       | 65   | 55        | 85   | 65        | 115  |
| <b>Fire Exposure R30</b>           | Tension $N_{Rk, fi}$ [kN] | 0,24    | 0,24   | 0,24  | 0,42     | 0,42 | 0,99      | 0,99 | 2,13      | 2,65 |
|                                    | Shear $V_{Rk, fi}$ [kN]   | 0,24    | 0,24   | 0,24  | 0,42     | 0,42 | 0,99      | 0,99 | 2,65      | 2,65 |
| <b>Fire Exposure R60</b>           | Tension $N_{Rk, fi}$ [kN] | 0,22    | 0,22   | 0,22  | 0,38     | 0,38 | 0,85      | 0,85 | 1,99      | 1,99 |
|                                    | Shear $V_{Rk, fi}$ [kN]   | 0,22    | 0,22   | 0,22  | 0,38     | 0,38 | 0,85      | 0,85 | 1,99      | 1,99 |
| <b>Fire Exposure R90</b>           | Tension $N_{Rk, fi}$ [kN] | 0,17    | 0,17   | 0,17  | 0,30     | 0,30 | 0,66      | 0,66 | 1,73      | 1,73 |
|                                    | Shear $V_{Rk, fi}$ [kN]   | 0,17    | 0,17   | 0,17  | 0,30     | 0,30 | 0,66      | 0,66 | 1,73      | 1,73 |
| <b>Fire Exposure R120</b>          | Tension $N_{Rk, fi}$ [kN] | 0,12    | 0,12   | 0,12  | 0,21     | 0,21 | 0,53      | 0,53 | 1,33      | 1,33 |
|                                    | Shear $V_{Rk, fi}$ [kN]   | 0,12    | 0,12   | 0,12  | 0,21     | 0,21 | 0,53      | 0,53 | 1,33      | 1,33 |

The recommended loads under fire exposure include a safety factor for resistance under fire exposure  $\gamma_{M,fi} = 1,0$  and the partial safety factor for action  $\gamma_{F,fi} = 1,0$ . The partial safety factors for action shall be taken from national regulations.

# FIRE RESISTANCE S-CSA A4

Design under fire exposure is performed according to the design method given in EN 1992-4.

The data of these tables is based on: ETA-22/0413

- Concrete C20/25,  $f_{ck,cube} = 25 \text{ N/mm}^2$
- Values cannot be used with hollow core slabs
- Installation has been done correctly (p.17)
- No influence of edge distances and spacings (p. 17)
- Respect of minimum base material thickness (p. 17)



## Characteristic resistances, S-CSA A4

|                                    |                           | S-CSA A4<br>6 |      | S-CSA A4<br>8 |      | S-CSA A4<br>10 |      |
|------------------------------------|---------------------------|---------------|------|---------------|------|----------------|------|
|                                    |                           | OPT 1         |      | OPT 1         |      | OPT 1          |      |
| Effective anchorage depth $h_{ef}$ | [mm]                      | 34,0          | 42,5 | 35,8          | 48,5 | 39,1           | 64,6 |
| Nominal anchorage depth $h_{nom}$  | [mm]                      | 45            | 55   | 50            | 65   | 55             | 85   |
| <b>Fire Exposure R30</b>           | Tension $N_{Rk, fi}$ [kN] | 0,24          | 0,24 | 0,75          | 0,85 | 1,70           | 1,70 |
|                                    | Shear $V_{Rk, fi}$ [kN]   | 0,24          | 0,24 | 0,85          | 0,85 | 1,70           | 1,70 |
| <b>Fire Exposure R60</b>           | Tension $N_{Rk, fi}$ [kN] | 0,22          | 0,22 | 0,68          | 0,68 | 1,36           | 1,36 |
|                                    | Shear $V_{Rk, fi}$ [kN]   | 0,22          | 0,22 | 0,68          | 0,68 | 1,36           | 1,36 |
| <b>Fire Exposure R90</b>           | Tension $N_{Rk, fi}$ [kN] | 0,17          | 0,17 | 0,51          | 0,51 | 1,09           | 1,09 |
|                                    | Shear $V_{Rk, fi}$ [kN]   | 0,17          | 0,17 | 0,51          | 0,51 | 1,09           | 1,09 |
| <b>Fire Exposure R120</b>          | Tension $N_{Rk, fi}$ [kN] | 0,12          | 0,12 | 0,42          | 0,42 | 0,95           | 0,95 |
|                                    | Shear $V_{Rk, fi}$ [kN]   | 0,12          | 0,12 | 0,42          | 0,42 | 0,95           | 0,95 |

The recommended loads under fire exposure include a safety factor for resistance under fire exposure  $\gamma_{M,fi} = 1,0$  and the partial safety factor for action  $\gamma_{F,fi} = 1,0$ . The partial safety factors for action shall be taken from national regulations.

# MATERIALS AND DIMENSIONS

## Material quality and coating S-CSA / S-CSA+

**Part**

|            |  |
|------------|--|
| Coating ZP | Zinc electroplated according to EN ISO 4042 $\geq 5 \mu\text{m}$ |
| Coating ML | Multi Layer coating $\geq 8 \mu\text{m}$                         |

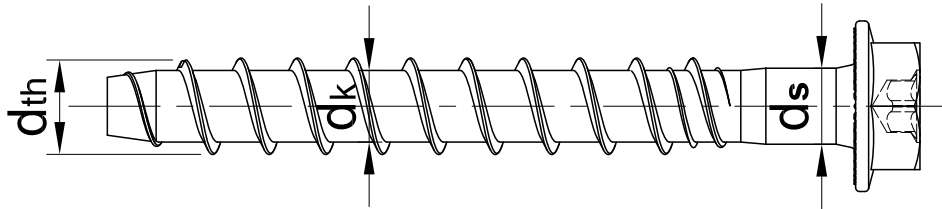

## Mechanical properties S-CSA / S-CSA+

| Specification                  |              |                      | S-CSA 5 |      | S-CSA 6 |      |      | S-CSA+ 8 |      | S-CSA+ 10 |      | S-CSA+ 14 |       |
|--------------------------------|--------------|----------------------|---------|------|---------|------|------|----------|------|-----------|------|-----------|-------|
| Effective anchorage depth      | $h_{ef}$     | [mm]                 | 19      | 27,5 | 27,6    | 31,9 | 42,5 | 39,2     | 51,9 | 42,5      | 68   | 49,3      | 91,8  |
| Nominal anchorage depth        | $h_{nom}$    | [mm]                 | 35      | 45   | 35      | 40   | 55   | 50       | 65   | 55        | 85   | 65        | 115   |
| Nominal Tension strength       | $F_{uk}$     | [N/mm <sup>2</sup> ] | 800     |      | 800     |      |      | 800      |      | 800       |      | 800       |       |
| Char. bending resistance       | $M_{Rk,s}^0$ | [Nm]                 | 8,6     |      | 16      |      |      | 37       | 45   | 72        | 84   | 207       | 227   |
| Design bending resistance      | $M_{Rd,s}$   | [Nm]                 | 5,7     |      | 12,8    |      |      | 29,6     | 36   | 57,6      | 67,2 | 165,6     | 181,6 |
| Recommended bending resistance | $M_{rec}$    | [Nm]                 | 4,1     |      | 9,1     |      |      | 21,1     | 25,7 | 41,1      | 48   | 118,3     | 129,7 |

| Specification                |           |                    | S-CSA 5 |  | S-CSA 6 |  | S-CSA+ 8 |  | S-CSA+ 10 |  | S-CSA+ 14 |  |
|------------------------------|-----------|--------------------|---------|--|---------|--|----------|--|-----------|--|-----------|--|
| Nominal diameter             | $d_{nom}$ | [mm]               | 5,0     |  | 6,0     |  | 8,0      |  | 10,0      |  | 14,0      |  |
| Thread outer diameter        | $d_{th}$  | [mm]               | 6,12    |  | 7,45    |  | 10,50    |  | 12,70     |  | 16,55     |  |
| Core diameter                | $d_k$     | [mm]               | 4,50    |  | 5,55    |  | 7,30     |  | 9,15      |  | 13,00     |  |
| Shaft diameter               | $d_s$     | [mm]               | 4,9     |  | 5,88    |  | 7,80     |  | 9,62      |  | 13,40     |  |
| Stressed section             | $A_s$     | [mm <sup>2</sup> ] | 15,9    |  | 24,19   |  | 42,43    |  | 65,76     |  | 132,73    |  |
| Diameter of flange (HEX)     | D         | [mm]               | 11,5    |  | 16,5    |  | 17,5     |  | 20,5      |  | 28/29,5   |  |
| Diameter of flange (I)       | D         | [mm]               | -       |  | 14,2    |  | -        |  | -         |  | -         |  |
| Diameter of pan head (P)     | D         | [mm]               | -       |  | 14,5    |  | -        |  | -         |  | -         |  |
| Diameter of countersunk (CS) | D         | [mm]               | 9,8     |  | 14      |  | -        |  | -         |  | -         |  |

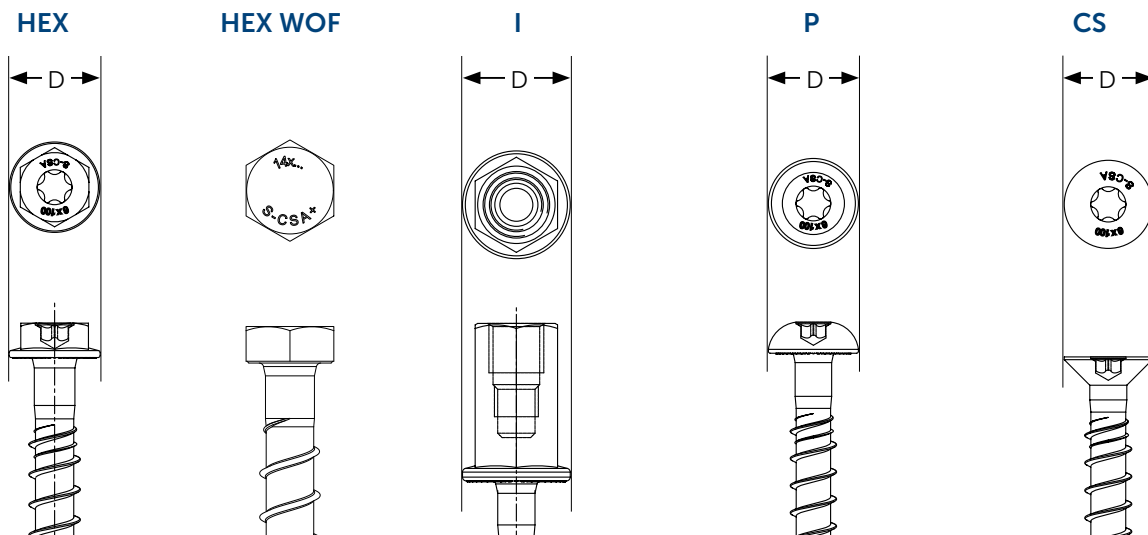

**Material quality and coating S-CSA A4**

**Part**

Material Cold forged stainless steel A4, hardened steel tip

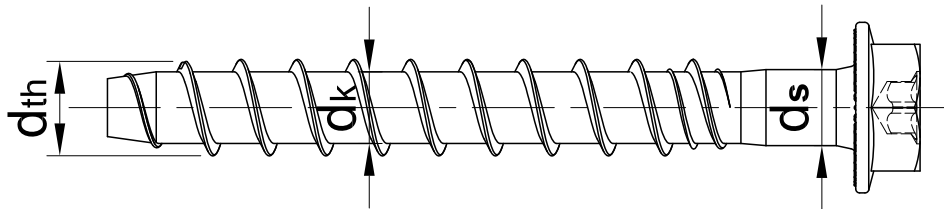

**Mechanical properties**

| Specification                  |              |                      | S-CSA A4 6 |      | S-CSA A4 8 |      | S-CSA A4 10 |      |
|--------------------------------|--------------|----------------------|------------|------|------------|------|-------------|------|
| Effective anchorage depth      | $h_{ef}$     | [mm]                 | 34         | 42,5 | 35,8       | 48,5 | 39,1        | 64,6 |
| Nominal anchorage depth        | $h_{nom}$    | [mm]                 | 45         | 55   | 50         | 65   | 55          | 85   |
| Nominal Tension strength       | $F_{uk}$     | [N/mm <sup>2</sup> ] | 800        |      | 800        |      | 705         |      |
| Char. bending resistance       | $M^0_{Rk,s}$ | [Nm]                 | 19,4       |      | 45,6       |      | 75,1        |      |
| Design bending resistance      | $M_{Rd,s}$   | [Nm]                 | 12,9       |      | 30,4       |      | 50,1        |      |
| Recommended bending resistance | $M_{rec}$    | [Nm]                 | 9,2        |      | 21,7       |      | 35,8        |      |

| Specification                |           |                    | S-CSA A4 6 | S-CSA A4 8 | S-CSA A4 10 |
|------------------------------|-----------|--------------------|------------|------------|-------------|
| Nominal diameter             | $d_{nom}$ | [mm]               | 6,0        | 8,0        | 10,0        |
| Thread outer diameter        | $d_{th}$  | [mm]               | 6          | 8          | 10          |
| Core diameter                | $d_k$     | [mm]               | 7,45       | 9,9        | 11,9        |
| Shaft diameter               | $d_s$     | [mm]               | 5,55       | 7,35       | 9,3         |
| Stressed section             | $A_s$     | [mm <sup>2</sup> ] | 5,9        | 7,85       | 9,67        |
| Diameter of flange (HEX)     | D         | [mm]               | 24,19      | 42,43      | 67,93       |
| Diameter of flange (I)       | D         | [mm]               | 16,5       | 17,5       | 20,5        |
| Diameter of pan head (P)     | D         | [mm]               | 14,5       | -          | -           |
| Diameter of countersunk (CS) | D         | [mm]               | 14         | -          | -           |

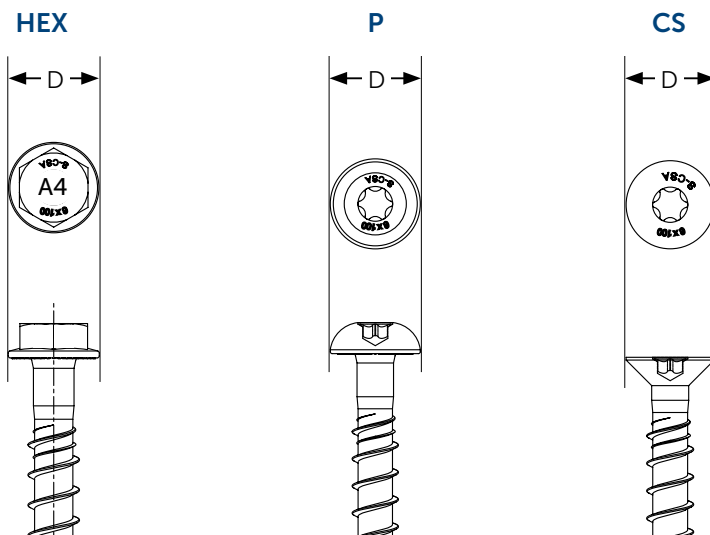

# INSTALLATION INSTRUCTIONS

## Installation equipment

| Specification    | S-CSA 5   | S-CSA 6 | S-CSA+ 8 | S-CSA+ 10 | S-CSA+ 14 | S-CSA 6 A4 | S-CSA 8 A4 | S-CSA 10 A4 |
|------------------|---|---------|----------|-----------|-----------|------------|------------|-------------|
| Rotary hammer    | 750...1200 r.p.m / 1.8 ...3.3 J                         |         |          |           |           |            |            |             |
| Drill bit        | SDS+ 2-CUT or 4-CUT sizes 5, 6, 8, 10, 14 mm            |         |          |           |           |            |            |             |
| Socket (SW) [mm] | 8   | 13      | 13       | 15        | 21 or 24  | 13         | 13         | 15          |
| T-drive / Torx   | T25   | T30     | -        | -         | -         | -          | -          | -           |
| Additional tools | air pump/compressor, torque wrench, impact screw driver |         |          |           |           |            |            |             |

## NOTES:

### CONCRETE AND HOLLOW CORE SLAB

- Concrete strength is C20/25 to C50/60  
Hollow core slabs C30/37 to C50/60
- No significant voids in concrete.
- Concrete is well compacted.
- Thickness of concrete is according PDS installation data.

### INSTALLATION

Edge distances and spacing are according PDS installation data.

- Use proper air pump or compressor.
- Drill hole is deep enough (mentioned  $h_1$  in PDS installation data).
- All dust should be cleaned from the hole to avoid screw jamming during installation.
- Pay special attention to cleaning, especially when installing downwards.
- In case of aborted hole, drilling of new hole at a minimum distance of twice the depth of the aborted hole, or smaller distance provided the aborted drill hole is filled with high strength non-shrinkage mortar. No shear or oblique tension loads are allowed in the direction of a not filled aborted hole.

### OTHER BASE MATERIALS

- Concrete screw can be used also in other base materials such as solid clay brick and solid sand-lime brick.

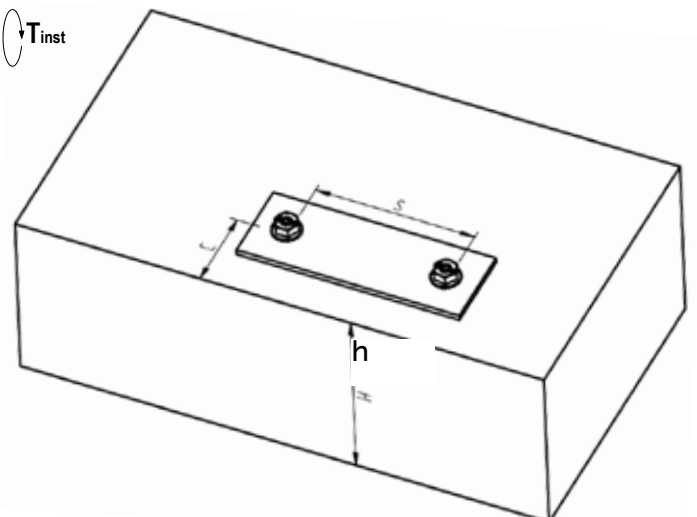
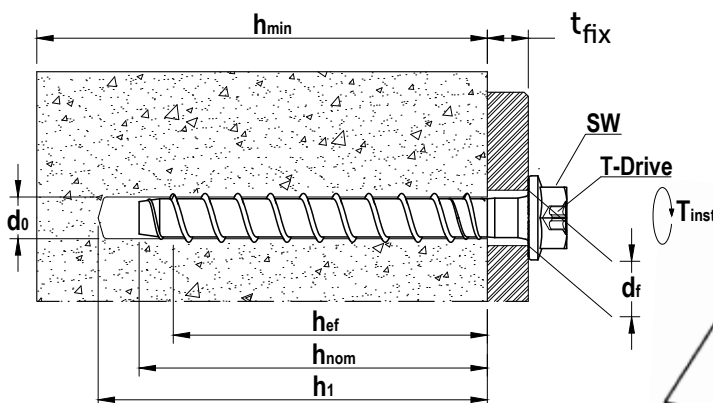
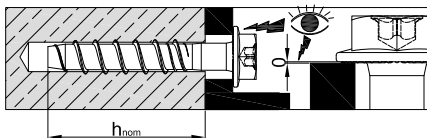
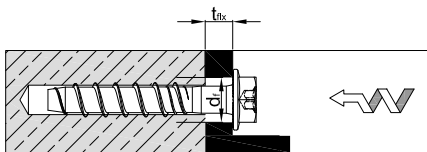
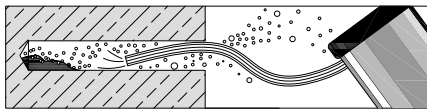
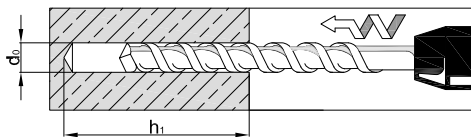

**Installation data S-CSA / S-CSA+**

| Specification  |                    |      | S-CSA 5 |      | S-CSA 6 |        |       | S-CSA+ 8  |       | S-CSA+ 10 |       | S-CSA+ 14 |      |
|--|--------------------|------|---------|------|---------|--------|-------|-----------|-------|-----------|-------|-----------|------|
| Approval   |                    |      | -       | -    | PART 6  | PART 6 | OPT 1 | OPT 1     | OPT 1 | OPT 1     | OPT 1 | OPT 1     |      |
| Drill hole diameter  | $d_0$              | [mm] | 5       |      | 6       |        |       | 8         |       | 10        |       | 14        |      |
| Cutting diameter at the upper tolerance limit (max. diam. bit) | $d_{cut,max} \leq$ | [mm] | 5,40    |      | 6,40    |        |       | 8,45      |       | 10,45     |       | 14,50     |      |
| Depth of drilled hole to deepest point                         | $h_{1 \geq}$       | [mm] | 45      | 55   | 45      | 50     | 65    | 60        | 75    | 65        | 95    | 75        | 125  |
| Effective anchorage depth                                      | $h_{ef}$           | [mm] | 19,0    | 27,5 | 27,6    | 31,9   | 42,5  | 39,2      | 51,9  | 42,5      | 68    | 49,3      | 91,8 |
| Nominal anchorage depth  | $h_{nom}$          | [mm] | 35      | 45   | 35      | 40     | 55    | 50        | 65    | 55        | 85    | 65        | 115  |
| Diameter of clearance hole in the fixture                      | $d_f$              | [mm] | 6,3-7,0 |      | 7,7-9,0 |        |       | 10,8-12,0 |       | 13,0-14,0 |       | 17,0-18,0 |      |
| Max. torque, manual  | $T_{inst}$         | [Nm] | 12      |      | 14      |        |       | 45        |       | 85        |       | 100       |      |
| Max. torque, impact screw driver                               | $T_{SD}$           | [Nm] | -       |      | 90      |        |       | 290       |       | 650       |       | 650       |      |
| Width across flats   | SW                 | [mm] | 8       |      | 13      |        |       | 13        |       | 15        |       | 21 / 24   |      |
| T-drive (in types HEX, CS and P)                               | T-drive            |      | CS      | T25  | T30     |        |       | -         |       | -         |       | -         |      |

**Minimum thickness of concrete member, spacing and edge distance S-CSA / S-CSA+**

| Cracked and non-cracked concrete   |             |      | S-CSA 5 |      | S-CSA 6 |       |       | S-CSA+ 8 |       | S-CSA+ 10 |       | S-CSA+ 14 |      |
|--|-------------|------|---------|------|---------|-------|-------|----------|-------|-----------|-------|-----------|------|
| Approval   |             |      | -       | -    | PART 6  | OPT 1 | OPT 1 | OPT 1    | OPT 1 | OPT 1     | OPT 1 |           |      |
| Effective anchorage depth  | $h_{ef}$    | [mm] | 19,0    | 27,5 | 27,6    | 31,9  | 42,5  | 39,2     | 51,9  | 42,5      | 68    | 49,3      | 91,8 |
| Nominal anchorage depth  | $h_{nom}$   | [mm] | 35      | 45   | 35      | 40    | 55    | 50       | 65    | 55        | 85    | 65        | 115  |
| Minimum thickness of base material   | $h_{min}$   | [mm] | 80      | 80   | 80      | 100   | 100   | 100      | 115   | 100       | 130   | 120       | 150  |
| Minimum spacing  | $s_{min}$   | [mm] | 35      | 35   | 35      | 35    | 35    | 35       | 35    | 40        | 40    | 60        | 60   |
| Minimum edge distance  | $c_{min}$   | [mm] | 35      | 35   | 30      | 35    | 35    | 35       | 35    | 40        | 40    | 60        | 60   |
| Critical <b>spacing</b> for splitting failure and concrete cone failure (in case characteristic loading affects)       | $s_{cr,sp}$ | [mm] | 53      | 83   | 110     | 96    | 128   | 118      | 176   | 128       | 232   | 148       | 275  |
|  | $s_{cr,N}$  | [mm] | 53      | 83   | 83      | 96    | 128   | 118      | 156   | 128       | 204   | 148       | 275  |
| Critical <b>edge distance</b> for splitting failure and concrete cone failure (in case characteristic loading affects) | $c_{cr,sp}$ | [mm] | 27      | 41   | 55      | 48    | 64    | 59       | 88    | 64        | 116   | 74        | 138  |
|  | $c_{cr,N}$  | [mm] | 27      | 41   | 41      | 48    | 64    | 59       | 78    | 64        | 102   | 74        | 138  |



# INSTALLATION S-CSA A4

## Installation data S-CSA A4

| Specification  |                    |      | S-CSA A4<br>6 |      | S-CSA A4<br>8 |      | S-CSA A4<br>10 |      |
|--|--------------------|------|---------------|------|---------------|------|----------------|------|
| <b>Approval</b>  |                    |      | OPT<br>1      |      | OPT<br>1      |      | OPT<br>1       |      |
| Drill hole diameter  | $d_0$              | [mm] | 6             |      | 8             |      | 101            |      |
| Cutting diameter at the upper tolerance limit (max. diam. bit) | $d_{cut,max \leq}$ | [mm] | 6,4           |      | 8,45          |      | 10,45          |      |
| Depth of drilled hole to deepest point                         | $h_{1 \geq}$       | [mm] | 55            | 65   | 60            | 75   | 65             | 95   |
| Effective anchorage depth                                      | $h_{ef}$           | [mm] | 34            | 42,5 | 35,8          | 48,5 | 39,1           | 64,6 |
| Nominal anchorage depth  | $h_{nom}$          | [mm] | 45            | 55   | 50            | 65   | 55             | 85   |
| Diameter of clearance hole in the fixture                      | $d_f$              | [mm] | $\leq 9$      |      | $\leq 12$     |      | $\leq 14$      |      |
| Max. torque, manual  | $T_{inst \leq}$    | [Nm] | 14            |      | 40            |      | 75             |      |
| Max. torque, impact screw driver                               | $T_{SD}$           | [Nm] | 90            |      | 290           |      | 360            |      |
| Width across flats   | SW                 | [mm] | 13            |      | 13            |      | 15             |      |
| T-drive<br>(in types CS and P)                                 | T-drive            |      | T30           |      | -             |      | -              |      |

## Minimum thickness of concrete member, spacing and edge distance S-CSA A4

| Cracked and non-cracked concrete   |             |      | S-CSA A4<br>6 |       | S-CSA A4<br>8 |       | S-CSA A4<br>10 |       |
|--|-------------|------|---------------|-------|---------------|-------|----------------|-------|
| <b>Approval</b>  |             |      | OPT<br>1      |       | OPT<br>1      |       | OPT<br>1       |       |
| Effective anchorage depth  | $h_{ef}$    | [mm] | 34            | 42,5  | 35,8          | 48,5  | 39,1           | 64,6  |
| Nominal anchorage depth  | $h_{nom}$   | [mm] | 45            | 55    | 50            | 65    | 55             | 85    |
| Minimum thickness of base material   | $h_{min}$   | f    | 80            | 100   | 100           | 100   | 100            | 100   |
| Minimum spacing  | $s_{min}$   | [mm] | 35            | 35    | 35            | 35    | 40             | 40    |
| Minimum edge distance  | $c_{min}$   | [mm] | 35            | 35    | 35            | 35    | 40             | 40    |
| Critical <b>spacing</b> for splitting failure and concrete cone failure (in case characteristic loading affects)       | $s_{cr,sp}$ | [mm] | 136,0         | 127,5 | 121,7         | 165,0 | 195,5          | 184,5 |
|  | $s_{cr,N}$  | [mm] | 102,0         | 127,5 | 107,4         | 145,5 | 117,3          | 193,8 |
| Critical <b>edge distance</b> for splitting failure and concrete cone failure (in case characteristic loading affects) | $c_{cr,sp}$ | [mm] | 68,0          | 63,8  | 60,9          | 82,5  | 97,8           | 92,3  |
|  | $c_{cr,N}$  | [mm] | 51,0          | 63,8  | 53,7          | 72,8  | 58,7           | 96,9  |

## S-CSA+ 14 REUSABILITY

DIBt Z-21.8-2136 approves the reuse of the S-CSA+ concrete screw, 14 mm diameter with hexagon head in combination with the CG checking gauge. The checking gauge is a tool for measuring the reusability of the S-CSA+ 14 concrete screw for temporary applications. The checking must be performed before each reuse.

### Field of application

S-CSA+ 14 shall only be applied for temporary fastening of construction site equipment, such as shoring props, fall protection devices or scaffolds. After it has been unscrewed, the fastener may be reused in other drill holes. However, a drilled hole shall not be reused after the fastener has been removed. Reusability of the fastener shall be checked prior to every use, both visually as well as with a sleeve gauge in accordance with installation parameters. Installed fasteners shall be checked for visible damage (for example due to corrosion) on an ongoing basis and replaced if required. The fastener may be used in cracked and non-cracked concrete. The fastener is intended for temporary use in internal and external conditions.

### Installation

S-CSA+ 14 is only intended for temporary application in a single drilled hole. After it has been removed, it may be reused in other drilled holes. However, it may not be screwed into the same drilled hole for a second time. Prior to every reuse, the wear of the thread shall be verified with an appropriate sleeve gauge (CG). The fastener shall only be reused under the condition that it will penetrate the sleeve only so far that it does not protrude at the rear of the sleeve (see Annex 2). Screws which are visibly damaged, e.g. due to corrosion, shall not be reused. The fastener may be screwed in using an impact screw driver. To prevent the screw from spinning, the screw driver with a power output in the upper range shall be equipped with an automatic cut-off device, e.g. via a depth stop.

The fastener is installed correctly if

- the base plate (fixture) is screwed flush against the concrete without an intermediate layer,
- the fastener head is fully in contact with the base plate,
- the fastener cannot easily be turned further,
- the embedment depth  $h_{nom}$  is adhered to.

| Anchor size   | S-CSA+ 14     |      |     |      |
|---|---------------|------|-----|------|
| Nominal embedment depth   | $h_{nom}$     | [mm] | 65  | 115  |
| Design resistance for concrete with a compressive strength $f_{ck,cube} \geq 10 \text{ N/mm}^2$ | $F_{Rd}^{1)}$ | [kN] | 2,7 | 6,7  |
| Design resistance for concrete with a compressive strength $f_{ck,cube} \geq 15 \text{ N/mm}^2$ | $F_{Rd}^{1)}$ | [kN] | 3,0 | 8,0  |
| Design resistance for concrete with a compressive strength $f_{ck,cube} \geq 20 \text{ N/mm}^2$ | $F_{Rd}^{1)}$ | [kN] | 3,0 | 9,3  |
| Design resistance for concrete with a compressive strength $f_{ck,cube} \geq 25 \text{ N/mm}^2$ | $F_{Rd}^{1)}$ | [kN] | 3,3 | 10,0 |

<sup>1)</sup> Design resistance incl. partial safety factor.

# S-CSA+ 14 REUSABILITY

## Checking gauge CG



### Gauge

Gauge inner diameter  $d_c$  15,5 [mm]

Length  $l_c$  40,0 [mm]

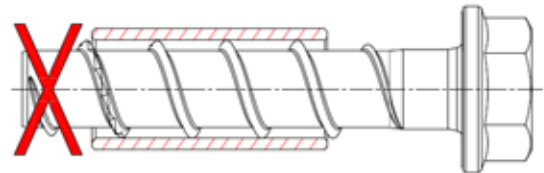
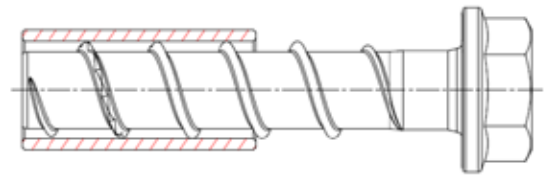
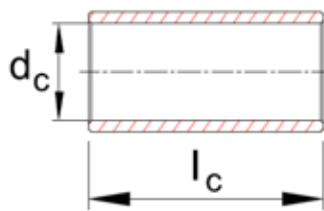

## DELIVERY PROGRAM

HEX, CS, I, P CONCRETE SCREWS

| S-CSA+ HEX         | Size        | t <sub>fix</sub> | ETA |
|--------------------|-------------|------------------|-----|
| 8                  | 8x55        | 5                | ●   |
|                    | 8x70        | 5/20             | ●   |
|                    | 8x80        | 15/30            | ●   |
|                    | 8x90        | 25/40            | ●   |
|                    | 8x100       | 35/50            | ●   |
|                    | 8x120       | 55/70            | ●   |
|                    | 8x140       | 75/90            | ●   |
| 10                 | 10x60       | 5                | ●   |
|                    | 10x70       | 15               | ●   |
|                    | 10x80       | 25               | ●   |
|                    | 10x90       | 5/35             | ●   |
|                    | 10x100      | 15/45            | ●   |
|                    | 10x120      | 35/65            | ●   |
|                    | 10x140      | 55/85            | ●   |
| 14                 | 10x160      | 75/105           | ●   |
|                    | 14x75 SW21  | 10               | ●   |
|                    | 14x100 SW21 | 35               | ●   |
|                    | 14x130 SW21 | 15/65            | ●   |
|                    | 14x150 SW21 | 35/85            | ●   |
| 14x80 SW24 (WOF) * | 15          | ●                |     |
| 14x110 SW24 *      | 45          | ●                |     |
| 14x130 SW24 *      | 15/65       | ●                |     |

Zinc plated or Multi Layer coating, \* = Only ZP

### S-CSA+ HEX 14 checking gauge for re-usability



| S-CSA HEX | Size   | t <sub>fix</sub> | ETA |
|-----------|--------|------------------|-----|
| 5         | 5x40 * | 5                | -   |
|           | 5x50 * | 5                | -   |
| 6         | 6x35   | 1                | ●   |
|           | 6x45   | 5/10             | ●   |
|           | 6x50   | 10/15            | ●   |
|           | 6x60   | 5/20             | ● ● |
|           | 6x70   | 15/30            | ● ● |
|           | 6x80   | 25/40            | ● ● |
|           | 6x100  | 45/60            | ● ● |
|           | 6x120  | 65/80            | ● ● |
|           | 6x140  | 85/100           | ● ● |

Zinc plated or Multi Layer coating, \* = Only ZP

| S-CSA CS | Size    | t <sub>fix</sub> ZP/ML | t <sub>fix</sub> A4 | ETA |
|----------|---------|------------------------|---------------------|-----|
| 5        | 5x50 *  | 5                      | -                   | -   |
|          | 5x75 *  | 30                     | -                   | -   |
|          | 5x100 * | 55                     | -                   | -   |
| 6        | 6x45    | 5/10                   | -                   | ●   |
|          | 6x50    | 10/15                  | 5                   | ●   |
|          | 6x60    | 5/20                   | 5/15                | ● ● |
|          | 6x70    | -                      | 15/25               | ● ● |
|          | 6x80    | 25/40                  | -                   | ● ● |
|          | 6x100   | 45/60                  | 45/55               | ● ● |
|          | 6x120   | 65/80                  | -                   | ● ● |

Zinc plated, Multi Layer coating or A4. \* = Only ZP

| S-CSA P | Size     | t <sub>fix</sub> ZP/ML | t <sub>fix</sub> A4 | ETA |
|---------|----------|------------------------|---------------------|-----|
| 6       | 6x35 (L) | 1                      | -                   | ●   |
|         | 6x45 (L) | 5                      | -                   | ●   |
|         | 6x50     | -                      | 5                   | ● ● |
|         | 6x60     | 5/20                   | 5/15                | ● ● |
|         | 6x80     | -                      | 25/35               | ● ● |

Zinc plated, Multi Layer or A4, L = Low pan head

| S-CSA I | Size           | ETA |
|---------|----------------|-----|
| 6       | 6x35 M8/M10x30 | ●   |
|         | 6x45 M8/M10x30 | ●   |
|         | 6x60 M8/M10x30 | ● ● |

Zinc plated

| S-CSA HEX A4 | Size   | t <sub>fix</sub> | ETA |
|--------------|--------|------------------|-----|
| 6            | 6x50   | 5                | ●   |
|              | 6x60   | 5/15             | ●   |
|              | 6x70   | 15/25            | ●   |
| 8            | 6x80   | 25/35            | ●   |
|              | 8x55   | 5                | ●   |
|              | 8x70   | 5/20             | ●   |
|              | 8x80   | 15/30            | ●   |
| 10           | 8x100  | 35/50            | ●   |
|              | 10x90  | 5/35             | ●   |
|              | 10x120 | 35/65            | ●   |

Stainless Steel A4, hardened tip, coated

● Option 1    ● Part 6