

THROUGH BOLTS

PRODUCT DATA SHEET

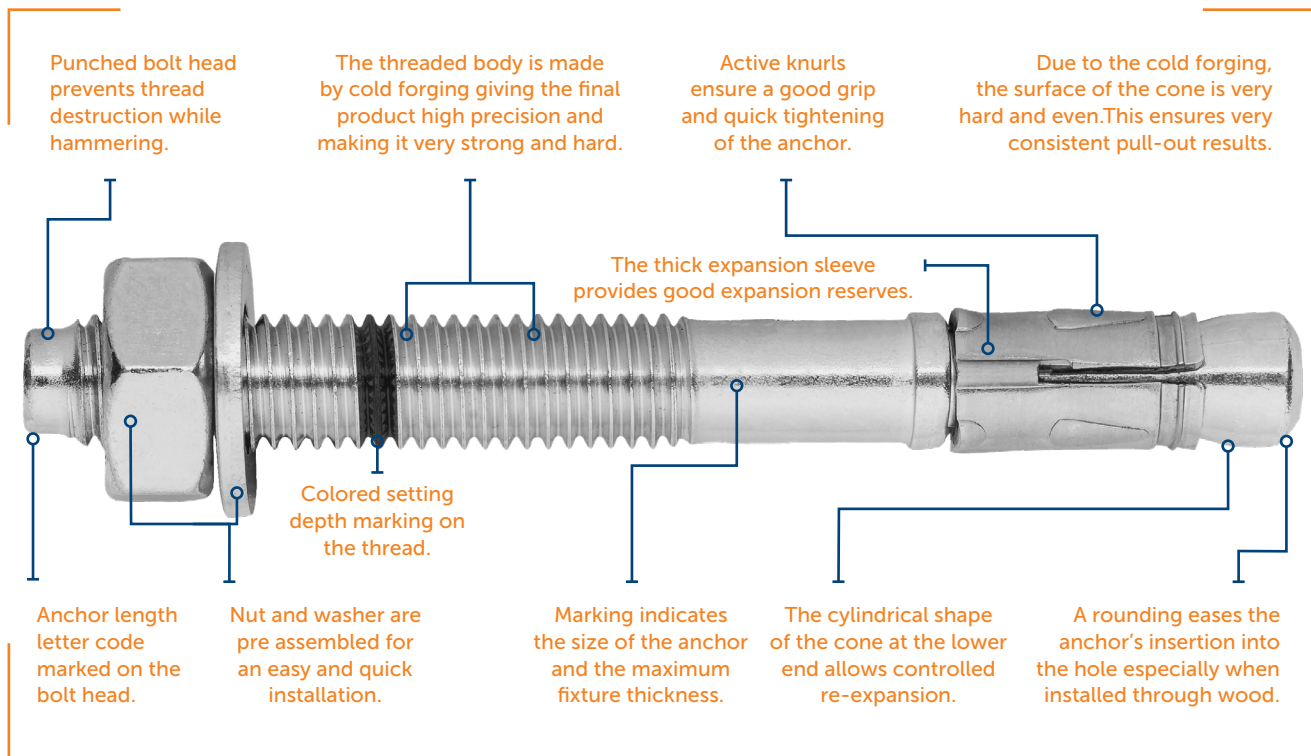

High performance through bolts+ for fixing in cracked and non-cracked concrete



THROUGH BOLTS

The through bolt is a torque-controlled expansion anchor for use in cracked and non-cracked concrete. The anchor is preassembled and can be installed directly through the fixture.

Available in

- Zinc electroplated steel for indoor and dry applications.
- Hot dip galvanized steel for damp interiors with occasional exposure to condensation and in non-safety-relevant slightly corrosive outside environments, when corrosion is inspected regularly.
- Stainless steel for outdoor applications subject to humidity, as well as installation in industrial and maritime environments.
- HCR stainless steel for aggressive conditions, chloride atmosphere and atmosphere with chemical pollution such as tunnels, swimming pools etc.

Benefits

- Fixing in cracked and non-cracked concrete, also suitable for natural stone
- Torque-controlled expansion anchors for pre-, push-through and distance installations
- When torque is applied the expansion clip expands developing frictional grip into the hole.
- Anchor diameter and max. fixture thickness marked on the body.
- Anchor length letter code marked on the bolt head.
- Colored setting depth marking for the deeper anchorage depth on the thread.
- Variable range of coatings and materials such as ZP, HDG, A4 and HCR 1.4529 which supports for anchor selecting in different applications
- Sormat Through bolts are manufactured reliably in Finland since 1970s



High performance through bolts+ for fixing in cracked and non-cracked concrete

S-KA+ carbon steel

Zinc electroplated acc. EN ISO 4042, $t \geq 5 \mu\text{m}$

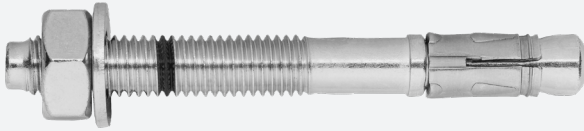

Dry indoor conditions, indoor with temporary condensation.

S-KAK+ carbon steel

Hot dip galvanized acc. EN ISO 10684, $t \geq 50 \mu\text{m}$

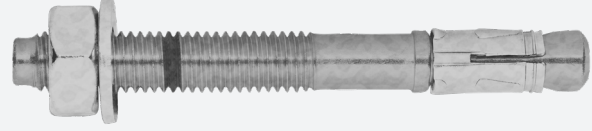

Humid indoor use, outdoor inland rural areas only in not safety relevant applications.

S-KAH+ A4 stainless steel

A4 for indoor, outdoor, industrial use and maritime climate

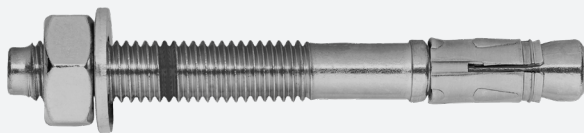

S-KAH+ A4 recommended when fire or corrosion resistance is required.

BA-E Plus HCR

HCR for extremely corrosive conditions,

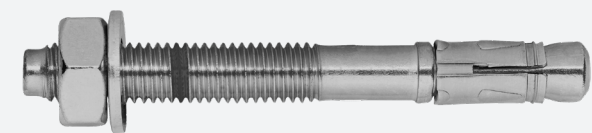

such as high chlorine concentrations (swimming halls), road tunnels and desulphurization plants.

Base materials

Approved for



Cracked concrete

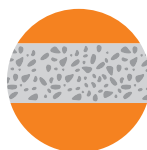

Non-cracked concrete

Also suitable for



Natural stone

Premium-quality M6 and M20 through bolts for fixing in cracked and non-cracked concrete

S-KA carbon steel

Zinc electroplated acc. EN ISO 4042, $t \geq 5 \mu\text{m}$



Dry indoor conditions, indoor with temporary condensation

S-KAK carbon steel

Hot dip galvanized acc. EN ISO 10684, $t \geq 40 \mu\text{m}$



Humid indoor use, outdoor inland rural areas only

S-KAH A4 stainless steel

A4 for indoor, outdoor, industrial use and maritime climate



S-KAH A4 recommended when fire or corrosion resistance is required.

S-KAR A2 stainless steel

A2 for dry and humid indoor use, outdoor in rural areas only



Suitable for minings and for fixing very thick fixtures, such a thermal insulation and wood structures to concrete

HHA A2 stainless steel

A2 for dry and humid indoor use, outdoor in rural areas only



Hammer hook anchor for suspension in tunnels and mines

Base materials

Approved for



Cracked concrete

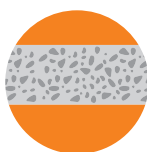

Non-cracked concrete

Also suitable for



Solid clay brick (M8 max)



Natural stone

Thought bolt Approvals / Certifications / Applications

Description of document		Authority/ Laboratory	ID	Additional info
European Technical Assessment		ZAG -National Building and Civil Engineering Institute, Slovenia	ETA-16/0934	EAD 330232-01-0601
Fire resistance		ZAG -National Building and Civil Engineering Institute, Slovenia	ETA-16/0934	EOTA TR 020 / EN 1992-4:2018
Seismic resistance		ZAG -National Building and Civil Engineering Institute, Slovenia	ETA-16/0934	EOTA TR 045
European Technical Assessment		ZAG -National Building and Civil Engineering Institute, Slovenia	ETA-18/0971	EAD 330747-00-0601
Fire resistance		ZAG -National Building and Civil Engineering Institute, Slovenia	ETA-18/0971	EOTA TR 020 / EN 1992-4:2018
Sormat Trustfix anchor calculation software		EJOT Sormat Oy / S&P Software Consulting		TrustFIX anchor calculation
Through bolts CAD-blocks for AutoCAD		EJOT Sormat Oy		Blocks installation instructions for AutoCAD
YouTube installation videos		EJOT Sormat Oy		

Additional information concerning all given data in the product data sheet

1. Load figures include the partial safety factors as per approvals and a partial safety factor on the action of $\gamma_F = 1.4$. Load figures apply for a rebar spacing $s \geq 15$ cm or alternatively for a rebar spacing $s \geq 10$ cm in combination with a rebar diameter of $d_s \leq 10$ mm.
2. If spacings or edge distances become smaller than the characteristic figures ($s_{cr,N} / c_{cr,N}$) a calculation as per EOTA TR 055 needs to be carried out. For more details, see ETA-16/0934.
3. Concrete is considered non-cracked when the value of tension within the concrete is $\sigma_L + \sigma_R \leq 0$. In the absence of detailed verification $\sigma_R = 3$ N/mm² can be assumed (σ_L equals the tension within the concrete as a result of external loads, forces on anchor included; σ_R equals the tension coming from shrinkage or creep of the concrete, as well as displacements of supports or temperature variations).
4. Shear load figures apply for an anchor without influence of a concrete edge. For shear loads close to an edge ($c \leq 10 \times h_{ef}$), concrete edge failure has to be checked as per EOTA TR 055.

Static and quasi-static loads

The data of these tables is based on:

- ETA-16/0934
- ETA-18/0971 : M6 for multiple use for non-structural applications in concrete.
- Concrete C20/25, $f_{ck,cube} = 25 \text{ N/mm}^2$.
- Installation has been done correctly (page 10).
- No influence of edge distances and spacings.
- Respect of minimum base material thickness (page 11).

Characteristic resistances

Anchor size				M6		M8		M10		M12		M16	M20
■ ETA-16/0934 ● ETA-18/0971				●	●	■	■	■	■	■	■	■	-
Effective anchorage depth h_{ef} [mm]				25	35	35	48	40	60	50	70	85	110
Non-cracked concrete	Tensile N_{Rk}	ZINC / HDG [kN]	2,0	3,5	8,0	11,0	12,0	19,0	17,4	25,0	36,0	41,6	
		A4 / HCR [kN]	3,0	5,0	8,0	11,0	12,0	19,0	17,4	25,0	36,0	41,6	
	Shear V_{Rk}	ZINC / HDG [kN]	4,3	4,3*	12,6*	12,6*	20,4*	20,4*	30,0*	30,0*	54,1*	58,2*	
		A4 / HCR [kN]	4,3	7,1	15,8*	15,8*	20,4*	20,4*	34,4*	34,4*	68,6*	58,2*	
Cracked concrete	Tensile N_{Rk}	ZINC / HDG [kN]	2,0	3,5	5,0	8,5	8,7	12,0	12,2	16,0	24,0	-	
		A4 / HCR [kN]	3,0	5,0	5,0	8,5	8,7	12,0	12,2	16,0	24,0	-	
	Shear V_{Rk}	ZINC / HDG [kN]	4,3	4,3*	12,6*	12,6*	20,4*	20,4*	34,6	30,0*	54,1*	-	
		A4 / HCR [kN]	4,3	7,1	15,8*	15,8*	20,4*	20,4*	34,6	34,4*	73,1	-	

Design resistances

Anchor size				M6		M8		M10		M12		M16	M20
■ ETA-16/0934 ● ETA-18/0971				●	●	■	■	■	■	■	■	■	-
Effective anchorage depth h_{ef} [mm]				25	35	35	48	40	60	50	70	85	110
Non-cracked concrete	Tensile N_{Rk}	ZINC / HDG [kN]	1,3	2,3	5,3	7,3	8,0	12,7	11,6	16,7	24,0	27,7	
		A4 / HCR [kN]	2,0	3,3	5,3	7,3	8,0	12,7	11,6	16,7	24,0	27,7	
	Shear V_{Rk}	ZINC / HDG [kN]	2,9	3,4*	10,1*	10,1*	16,3*	16,3*	24,0*	24,0*	43,3*	38,8*	
		A4 / HCR [kN]	2,9	4,7	12,6*	12,6*	16,3*	16,3*	27,5*	27,5*	54,9*	38,8*	
Cracked concrete	Tensile N_{Rk}	ZINC / HDG [kN]	1,3	2,3	3,3	5,7	5,8	8,0	8,1	10,7	16,0	-	
		A4 / HCR [kN]	2,0	3,3	3,3	5,7	5,8	8,0	8,1	10,7	16,0	-	
	Shear V_{Rk}	ZINC / HDG [kN]	2,9	3,4*	10,1*	10,1*	16,3*	16,3*	23,1	24,0*	43,3*	-	
		A4 / HCR [kN]	2,9	4,7	10,5	12,6*	16,3*	16,3*	23,1	27,5*	48,7	-	

Recommended loads

Anchor size				M6		M8		M10		M12		M16	M20
■ ETA-16/0934 ● ETA-18/0971				●	●	■	■	■	■	■	■	■	-
Effective anchorage depth h_{ef} [mm]				25	35	35	48	40	60	50	70	85	110
Non-cracked concrete	Tensile N_{Rk}	ZINC / HDG [kN]	1,0	1,7	3,8	5,2	5,7	9,0	8,3	11,9	17,1	19,8	
		A4 / HCR [kN]	1,4	2,4	3,8	5,2	5,7	9,0	8,3	11,9	17,1	19,8	
	Shear V_{Rk}	ZINC / HDG [kN]	2,0	2,5*	7,2*	7,2*	11,7*	11,7*	17,1*	17,1*	30,9*	27,7*	
		A4 / HCR [kN]	2,0	3,4	9,0*	9,0*	11,7*	11,7*	19,7*	19,7*	39,2*	27,7*	
Cracked concrete	Tensile N_{Rk}	ZINC / HDG [kN]	1,0	1,7	2,4	4,0	4,1	5,7	5,8	7,6	11,4	-	
		A4 / HCR [kN]	1,4	2,4	2,4	4,0	4,1	5,7	5,8	7,6	11,4	-	
	Shear V_{Rk}	ZINC / HDG [kN]	2,0	2,5*	7,2*	7,2*	11,7*	11,7*	16,5	17,1*	30,9*	-	
		A4 / HCR [kN]	2,0	3,4	7,5	9,0*	11,7*	11,7*	16,5	19,7*	34,8	-	

■ ETA-16/0934 ● ETA-18/0971 * Failure mode = steel

Seismic resistance

Design acc. EOTA TR 045: Performance category C2

The data of these tables is based on:

- Concrete C20/25, $f_{ck,cube} = 25 \text{ N/mm}^2$.
- Installation has been done correctly (see page 10).
- No influence of edge distances and spacings.
- Respect of minimum base material thickness (see page 11).



Characteristic resistances

Anchor size		M8	M10	M12	M16	
Effective anchorage depth h_{ef}	[mm]	48	60	70	85	
Cracked concrete						
Tensile $N_{Rk, seis}$	S-KA+	[kN]	1,7	4,6	6,7	15,9
	S-KAH+	[kN]	3,6	4,5	7,6	19,3
Shear $V_{Rk, seis}$	S-KA+	[kN]	4,8*	4,3*	6,9*	15,4*
	S-KAH+	[kN]	4,2*	4,7*	7,2*	15,4*

Design resistances

Anchor size		M8	M10	M12	M16	
Effective anchorage depth h_{ef}	[mm]	48	60	70	85	
Cracked concrete						
Tensile $N_{Rd, seis}$	S-KA+	[kN]	1,1	3,1	4,5	10,6
	S-KAH+	[kN]	2,4	3,0	5,1	12,9
Shear $V_{Rd, seis}$	S-KA+	[kN]	3,8*	3,4*	5,5*	12,3*
	S-KAH+	[kN]	3,4*	3,8*	5,8*	12,3*

Recommended loads

Anchor size		M8	M10	M12	M16	
Effective anchorage depth h_{ef}	[mm]	48	60	70	85	
Cracked concrete						
Tensile $N_{Rec, seis}$	S-KA+	[kN]	0,8	2,2	3,2	7,6
	S-KAH+	[kN]	1,7	2,1	3,6	9,2
Shear $V_{Rec, seis}$	S-KA+	[kN]	2,7*	2,4*	3,9*	8,8*
	S-KAH+	[kN]	2,4*	2,7	4,1*	8,8*

α_{seis} and α_{gap} included as per EOTA TR 045. The values don't consider any filling of the annular gap between the anchor and the fixture.

* Failure mode = steel

Fire resistance

The data of these tables is based on:

- ETA-16/0934 (M8, M10, M12, M16)
- ETA-18/0971 (M6)
- In the absence of other national regulations the partial safety factor for resistance under fire exposure $\gamma_{M,fi} = 1,0$ is recommended
- Concrete C20/25, $f_{ck,cube} = 25 \text{ N/mm}^2$
- Installation has been done correctly (see page 10).
- No influence of edge distances and spacings.



Characteristic resistances

Anchor size			M6	M8		M10		M12		M16
Effective anchorage depth h_{ef}	[mm]		35	35	48	40	60	50	70	85
R30										
Tensile $N_{Rk,fi}$	ZINC / HDG	[kN]	0,16	1,25	1,31	1,82	2,09	3,05	3,05	5,69
	A4 / HCR	[kN]	0,16	1,25	2,13	1,82	3,00	3,18	4,00	6,00
Shear $V_{Rk,fi}$	ZINC / HDG	[kN]	0,16	1,31	1,31	2,09	2,09	3,05	3,05	5,69
	A4 / HCR	[kN]	0,16	2,76	3,92	6,02	6,66	9,03	10,25	19,09
R60										
Tensile $N_{Rk,fi}$	ZINC / HDG	[kN]		1,05	1,05	1,66	1,66	2,40	2,40	4,47
	A4 / HCR	[kN]		1,25	2,13	1,82	3,00	3,18	4,00	6,00
Shear $V_{Rk,fi}$	ZINC / HDG	[kN]		1,05	1,05	1,66	1,66	2,40	2,40	4,47
	A4 / HCR	[kN]		2,70	2,70	4,59	4,59	7,07	7,07	13,16
R90										
Tensile $N_{Rk,fi}$	ZINC / HDG	[kN]		0,80	0,80	1,24	1,24	1,74	1,74	3,25
	A4 / HCR	[kN]		1,25	1,48	1,82	2,52	3,18	3,88	6,00
Shear $V_{Rk,fi}$	ZINC / HDG	[kN]		0,80	0,80	1,24	1,24	1,74	1,74	3,25
	A4 / HCR	[kN]		1,48	1,48	2,52	2,52	3,88	3,88	7,23
R120										
Tensile $N_{Rk,fi}$	ZINC / HDG	[kN]	0,08	0,67	0,67	1,02	1,02	1,41	1,41	2,64
	A4 / HCR	[kN]	0,08	0,87	0,87	1,46	1,48	2,29	2,29	4,26
Shear $V_{Rk,fi}$	ZINC / HDG	[kN]	0,08	0,67	0,67	1,02	1,02	1,41	1,41	2,64
	A4 / HCR	[kN]	0,08	0,87	0,87	1,48	1,48	2,29	2,29	4,26

Recommended loads

Anchor size			M6	M8		M10		M12		M16
Effective anchorage depth h_{ef}	[mm]		35	35	48	40	60	50	70	85
R30										
Tensile $N_{Rec,fi}$	ZINC / HDG	[kN]	0,16	1,25	1,31	1,82	2,09	3,05	3,05	5,69
	A4 / HCR	[kN]	0,16	1,25	2,13	1,82	3,00	3,18	4,00	6,00
Shear $V_{Rec,fi}$	ZINC / HDG	[kN]	0,16	1,31	1,31	2,09	2,09	3,05	3,05	5,69
	A4 / HCR	[kN]	0,16	2,76	3,92	6,02	6,66	9,03	10,25	19,09
R60										
Tensile $N_{Rec,fi}$	ZINC / HDG	[kN]		1,05	1,05	1,66	1,66	2,40	2,40	4,47
	A4 / HCR	[kN]		1,25	2,13	1,82	3,00	3,18	4,00	6,00
Shear $V_{Rec,fi}$	ZINC / HDG	[kN]		1,05	1,05	1,66	1,66	2,40	2,40	4,47
	A4 / HCR	[kN]		2,70	2,70	4,59	4,59	7,07	7,07	13,16
R90										
Tensile $N_{Rec,fi}$	ZINC / HDG	[kN]		0,80	0,80	1,24	1,24	1,74	1,74	3,25
	A4 / HCR	[kN]		1,25	1,48	1,82	2,52	3,18	3,88	6,00
Shear $V_{Rec,fi}$	ZINC / HDG	[kN]		0,80	0,80	1,24	1,24	1,74	1,74	3,25
	A4 / HCR	[kN]		1,48	1,48	2,52	2,52	3,88	3,88	7,23
R120										
Tensile $N_{Rec,fi}$	ZINC / HDG	[kN]	0,08	0,67	0,67	1,02	1,02	1,41	1,41	2,64
	A4 / HCR	[kN]	0,08	0,87	0,87	1,46	1,48	2,29	2,29	4,26
Shear $V_{Rec,fi}$	ZINC / HDG	[kN]	0,08	0,67	0,67	1,02	1,02	1,41	1,41	2,64
	A4 / HCR	[kN]	0,08	0,87	0,87	1,48	1,48	2,29	2,29	4,26

Anchor dimensions

Anchor size		M6	M8	M10	M12	M16	M20
Total length	L [mm]	40...100	57...420	62...420	78...420	118...420	170...280
Sleeve length	L_s [mm]	14,5	14,8	17,9	19,1	26,0	32,4
Thread length	L_t [mm]	18...60					55
Bolt body	d_{nom} [mm]	6	8	10	12	16	20
Hexagonal nut	SW [mm]	10	13	17	19	24	30
	m	$\geq 4,9$	$\geq 6,5$	$\geq 8,0$	$\geq 10,0$	$\geq 13,0$	$\geq 15,0$

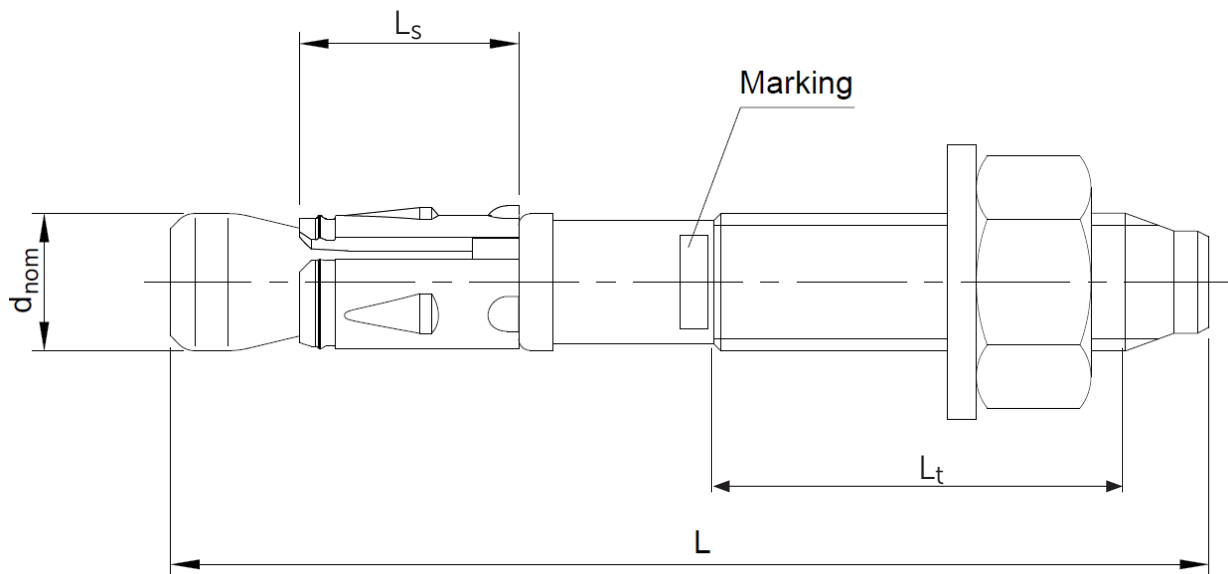

Mechanical properties

Specification			M6	M8	M10	M12	M16	M20
Nominal tensile strength $F_{uk,thread}$	ZINC / HDG	[N/mm ²]	500	700	690	690	660	475
	A4 / HCR	[N/mm ²]	620	670	690	690	645	475
Char. bending resistance $M_{Rk,s}^0$	ZINC / HDG	[Nm]	7	26,3	51	90	219,8	308
	A4 / HCR	[Nm]	9	25,1	51	90	214,8	308
Design bending resistance $M_{Rd,s}$	ZINC / HDG	[Nm]	5,6	21,0	40,8	72,0	175,8	205,3
	A4 / HCR	[Nm]	7,2	20,1	40,8	72,0	171,8	205,3
Recommended bending moment M_{Rec}	ZINC / HDG	[Nm]	4,0	15,0	29,1	51,4	125,6	146,7
	A4 / HCR	[Nm]	5,1	14,3	29,1	51,4	122,7	146,7

Material quality

Part of anchor	Material
S-KA+ / S-KA	Carbon steel, zinc electroplated EN ISO 4042, min. 5 μ m
S-KAK	Carbon steel, hot dip galvanized EN ISO 10684, EN ISO 1461, min. 40 μ m (M6 = min. 20 μ m)
Bolt S-KAK+	Carbon steel, hot dip galvanized EN ISO 10684, min. 50 μ m
S-KAH+ / S-KAH	Stainless steel A4
BA-E Plus HCR	Stainless steel HCR 1.4529

SETTING INSTRUCTIONS

Installation equipment

Specification	M6	M8	M10	M12	M16	M20
Rotary hammer (recommendation)	750...1200 r.p.m / 1.8...3.3 J					
				360...550 r.p.m / 4.9...11.5 J		
Setting tool (optional)	M6 - M10 SDS+			M12 - M20 SDS+		
Drill bit	SDS+ 2-CUT/4-CUT 8 mm...16 mm					
Additional tools	brush, air pump/compressor, hammer, torque wrench					

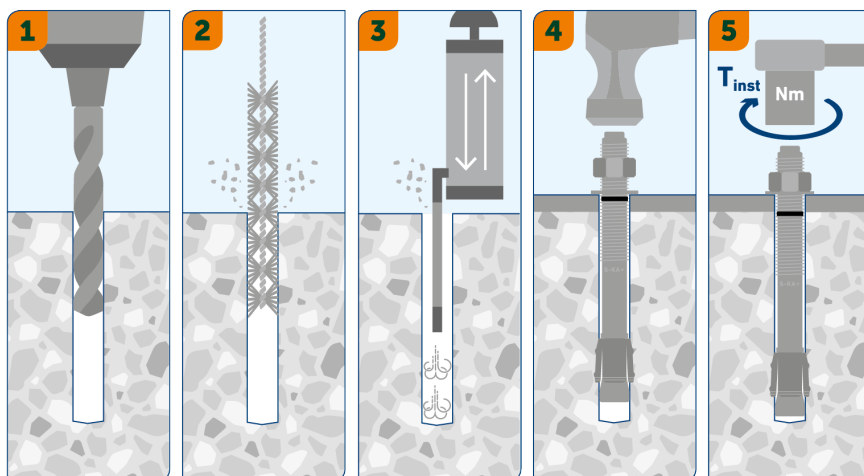

INSTALLATION

1. Drill a hole according to the product data.
- 2.-3. Clean the hole using a metal brush and a blow-out pump.
4. Install anchor with a hammer or a setting tool.
5. Tighten the anchor to the specified installation torque.

Installation data

Parameters and anchor sizes		M6	M8	M10	M12	M16	M20				
Drill hole diameter	d_0 [mm]	6	8	10	12	16	20				
Diameter of the drill bit at the upper tolerance limit	$d_{cut,max} \leq$ [mm]	6,40	8,45	10,45	12,50	16,50	20,55				
Depth of drilled hole to deepest point	$h_1 \geq$ [mm]	35	45	47	60	55	75	70	90	110	135
Effective anchorage depth	h_{ef} [mm]	25	35	35	48	40	60	50	70	85	110
Nominal anchorage depth	h_{nom} [mm]	30	40	40	53	48	68	61	81	97	125
Diameter of clearance hole in the fixture	$d_f \leq$ [mm]	7	9	12	14	18	22				
Width across flats	SW [mm]	10	13	17	19	24	30				
Required torque	ZINC / HDG	4	7	15	30	60	110	240			
	A4 / HCR	5	8	20	45	60	110	240			
	T_{inst} [Nm]										

Installation methods

Push-through installation

Distance installation

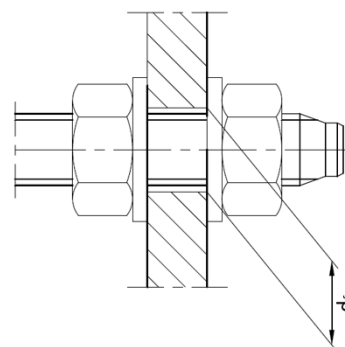
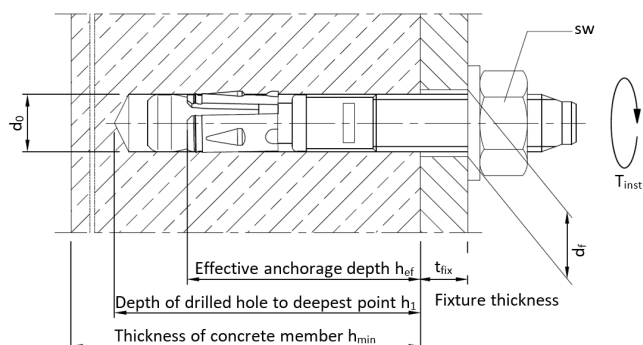

Minimum thickness of concrete member, spacing and edge distance

Cracked and non-cracked concrete			M6		M8		M10		M12		M16	M20
Effective anchorage depth	h_{ef}	[mm]	25	35	35	48	40	60	50	70	85	110
Minimum thickness of base material	h_{min}	[mm]	80	80	80	100	100	120	100	140	170	180
	$h_{min-red}$	[mm]	-	-	-	80	-	100	-	-	-	-
Minimum spacing for h_{min}	s_{min}	[mm]	50	40	55	35	50	40	55	60	65	400
	$c \geq$	[mm]	50	40	75	50	95	60	110	70	95	300
Minimum edge distance for h_{min}	c_{min}	[mm]	50	40	40		50		60	55	65	300
	$s \geq$	[mm]	50	40	140	55	190	100	215	110	150	400
Minimum spacing for $h_{min-red}$	s_{min}	[mm]	-	-	-	35	-	40	-	-	-	-
	$c \geq$	[mm]	-	-	-	55	-	100	-	-	-	-
Minimum edge distance for $h_{min-red}$	c_{min}	[mm]	-	-	-	40	-	60	-	-	-	-
	$s \geq$		-	-	-	60	-	90	-	-	-	-
Critical spacing for splitting failure and concrete cone failure (in case characteristic loading affects)	$s_{cr,sp}$	[mm]	140	120	170	192	160	240	200	280	340	-
	$s_{cr,N}$	[mm]	75	105	106	144	120	180	150	210	254	400
Critical edge distance for splitting failure and concrete cone failure (in case characteristic loading affects)	$c_{cr,sp}$	[mm]	70	60	85	96	80	120	100	140	170	-
	$c_{cr,N}$	[mm]	37,5	52,5	53	72	60	90	75	105	127	300

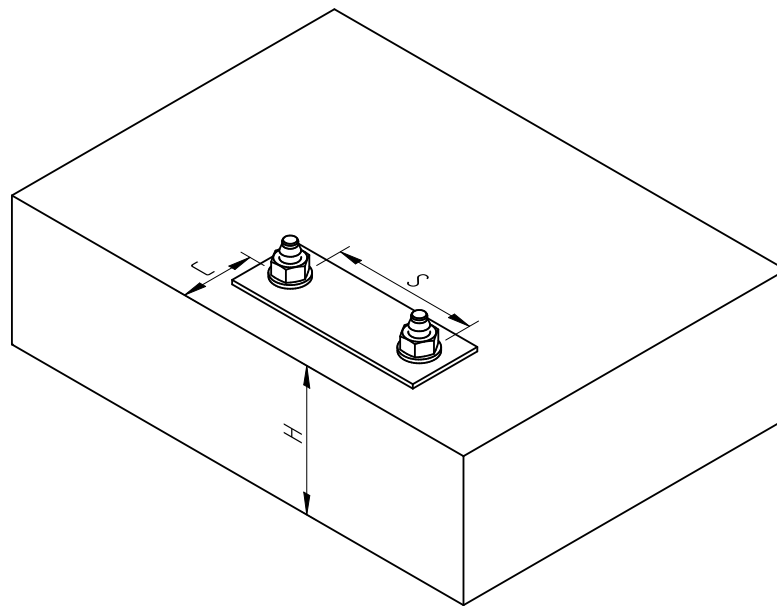

Setting tool S-KA SDS+

Hammering tool to make through bolt installation quicker and smoother

- Original Sormat through bolts setting tool with designed head that does not damage the head of the anchor and keep the head from slipping.
- Besides ensuring most efficient and safe through bolt installation in general, the setting tool also significantly saves time and energy in serial installation.
- Compatible with all rotary hammer machines with SDS+ chuck.



THROUGH BOLTS+

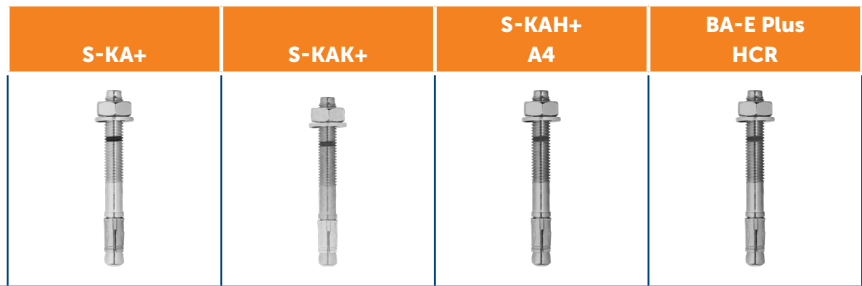

Thread size	Type	t _{fix}	Length	Zinc	HDG	Stainless A4	HCR
M8	M8/5/-	5	57	●	●	●	
	M8/23/10	23/10	75	●	●	●	●
	M8/43/30	43/30	95	●	●	●	
	M8/63/50	63/50	115	●	●	●	
	M8/98/85	98/85	150	●	●	●	
M10	M10/10/-	10/-	72	●	●	●	●
	M10/30/10	30/10	92	●	●	●	
	M10/40/20	40/20	102	●	●	●	
	M10/50/30	50/30	112	●	●	●	●
	M10/70/50	70/50	132	●	●	●	
M10/100/80	100/80	162	●	●	●		
M12	M12/10/-	10/-	88	●	●	●	
	M12/25/5	25/5	103	●	●	●	
	M12/40/20	40/20	118	●	●	●	
	M12/50/30	50/30	128	●	●	●	
	M12/70/50	70/50	148	●	●	●	
	M12/85/65	85/65	163	●	●	●	
M12/100/80	100/80	178	●	●	●		
M16	M16/5	5	123	●	●	●	
	M16/20	20	138	●	●	●	
	M16/50	50	168	●	●	●	
	M16/60	60	178	●	●	●	

THROUGH BOLTS



Thread size	Type	t _{fix}	Length	Zinc	HDG	Stainless A4	A2
M6	6x40	2 mm	40 mm	●	●	●	
	6/15x65	15 mm	65 mm	●	●	●	
	6/50x100	50 mm	100 mm	●	●	●	
M8	8x200	130 mm	200 mm				○
	8x240	170 mm	240 mm				○
	8x300	230 mm	300 mm				○
M20	20/20x170	20 mm	170 mm	○	○	○	
	20/70x220	70 mm	220 mm	○	○	○	
	20/130x280	130 mm	280 mm	○	○	○	

● ETA approved, option 1 ● ETA approved, part 6 ○ No ETA