



ZAVOD ZA  
GRADBENIŠTVO  
SLOVENIJE

SLOVENIAN  
NATIONAL BUILDING  
AND CIVIL ENGINEERING  
INSTITUTE



Member of



[www.eota.eu](http://www.eota.eu)

**Dimičeva 12,  
1000 Ljubljana, Slovenija**

Tel.: +386 (0)1 280 44 72, +386 (0)1-280 45 37

Fax: +386 (0)1 280 44 84

e-mail: [info.ta@zag.si](mailto:info.ta@zag.si)

<http://www.zag.si>

## European Technical Assessment

**ETA-16/0934**  
of 02.08.2022

*English version prepared by ZAG*

### General Part

**Technical Assessment Body issuing the  
European Technical Assessment**

**ZAG Ljubljana**

**Trade name of the construction product**

**Sormat through bolts S-KA+, S-KAK+,  
S-KAH+, S-KAH+ HCR /  
EJOT through bolts BA-V Plus, BA-F  
Plus, BA-E Plus, BA-E Plus HCR**

**Product family to which the construction  
product belongs**

**33: Torque controlled expansion  
anchor of sizes M8, M10, M12 and  
M16 for use in concrete**

**Manufacturer**

**EJOT SORMAT OY  
Harjutie 5  
21290 RUSKO  
Finland  
[www.sormat.com](http://www.sormat.com)**

**Manufacturing plant**

**EJOT Sormat Plant 1**

**This European Technical Assessment  
contains**

**17 pages including 3 annexes, which form  
an integral part of the document**

**This European Technical Assessment is  
issued in according to Regulation (EU)  
No 305/2011, on the basis of**

**EAD 330232-01-0601,  
edition December 2019**

**This version replaces**

**ETA-16/0934 issued on 18.02.2022**

Translations of this European Technical Assessment in other languages shall fully correspond to the original issued document and should be identified as such.

Communication of this European Technical Assessment, including transmission by electronic means, shall be in full (excepted the confidential Annex(es) referred to above). However, partial reproduction may be made, with the written consent of the issuing Technical Assessment Body. Any partial reproduction has to be identified as such.

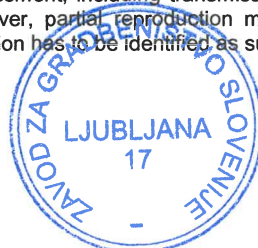

## Specific Parts

### 1 Technical description of the product

The Sormat through bolts S-KA+, S-KAK+, S-KAH+, S-KAH+ HCR / EJOT through bolts BA-V Plus, BA-F Plus, BA-E Plus, BA-E Plus HCR is an anchor made of zinc plated carbon steel (S-KA+ / BA-V Plus), hot dip galvanized carbon steel (S-KAK+ / BA-F Plus) stainless steel (S-KAH+ / BA-E Plus) and high corrosion resistant stainless steel (S-KAH+ HCR / BA-E Plus HCR). It consists of a bolt, expansion sleeve, hexagonal nut and washer.

Anchors are made in sizes M8, M10, M12 and M16. Anchor is placed into a drilled hole and anchored by torque-controlled expansion.

For the installed anchor see Figure given in Annex A(1/3).

### 2 Specification of the intended use(s) in accordance with the applicable European Assessment Document (hereinafter EAD)

The performances given in Chapter 3 are only valid if the anchor is used in compliance with the specifications and conditions given in Annex B.

The provisions made in this European Technical Assessment are based on an assumed working life of the anchor of 50 years. The indications given on the working life cannot be interpreted as a guarantee given by the manufacturer, but are to be regarded only as a means for choosing the right products in relation to the expected economically reasonable working life of the works.

### 3 Performance of the product and references to the methods used for its assessment

#### 3.1 Mechanical resistance and stability (BWR 1)

The basic work requirements for mechanical resistance and stability are listed in Annexes C (1/7) and C (2/7) for static and quasi-static loading and in Annexes C (6/7) and C (7/7) for seismic performance.

#### 3.2 Safety in case of fire (BWR 2)

The basic work requirements for safety in case of fire are listed in Annexes C (3/7) and C (4/7).

#### 3.3 General aspects relating to fitness for use

Durability and serviceability are only ensured if specifications of intended use according to Annex B (1/4) are kept.



**4 Assessment and verification of constancy of performance (hereinafter AVCP) system applied, with reference to its legal base**

According to the decision 96/582/EC of the European Commission<sup>1</sup> the system of assessment and verification of constancy of performance (see Annex V to regulation (EU) No 305/2011) 1 apply.

**5 Technical details necessary for the implementation of the AVCP system, as provided for on the applicable EAD**

Technical details necessary for the implementation of the AVCP system are laid down in chapter 3 of EAD 330232-01-0601.

Issued in Ljubljana on 02.08.2022

Signed by:

Franc Capuder, M.Sc., Research Engineer

*Head of Service of TAB*



---

<sup>1</sup> Official Journal of the European Communities L 254 of 8.10.1996

# SORMAT through bolt

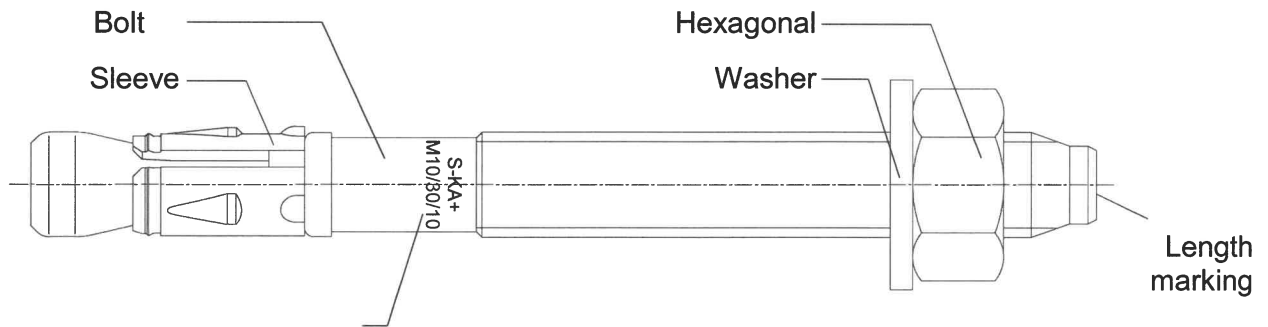

Marking:

<b>S-KA+ / BA-V Plus:</b>	S-KA+ M.../t <sub>fix,max</sub> /t <sub>fix,min</sub>	- zinc plated
<b>S-KAK+ / BA-F Plus:</b>	S-KAK+ M.../t <sub>fix,max</sub> /t <sub>fix,min</sub>	- hot dip galvanized
<b>S-KAH+ / BA-E Plus:</b>	S-KAH+ M.../t <sub>fix,max</sub> /t <sub>fix,min</sub>	- stainless steel A4
<b>S-KAH+ HCR / BA-E Plus HCR:</b>	S-KAH+ HCR M.../t <sub>fix,max</sub> /t <sub>fix,min</sub>	- high corrosion resistant

Length marking:

Length marking	A	B	C	D	E	F
Length (mm)	38,1-50,8	50,8-63,5	63,5-76,2	76,2-88,9	88,9-101,6	101,6-114,3

Length marking	G	H	I	J	K
Length (mm)	114,3-127,0	127,0-139,7	139,7-152,4	152,4-165,1	165,1-177,8

Length marking	L	M	N	O	P
Length (mm)	177,8-190,5	190,5-203,2	203,2-215,9	215,9-228,6	228,6-241,3

Length marking	Q	R	S
Length (mm)	241,3-254,0	254,0-279,4	279,4-304,8



**Sormat through bolts S-KA+, S-KAK+, S-KAH+, S-KAH+ HCR / EJOT through bolts BA-V Plus, BA-F Plus, BA-E Plus, BA-E Plus HCR**

**Product description**

Product

**Annex A (1/3)**

# SORMAT through bolt after installation

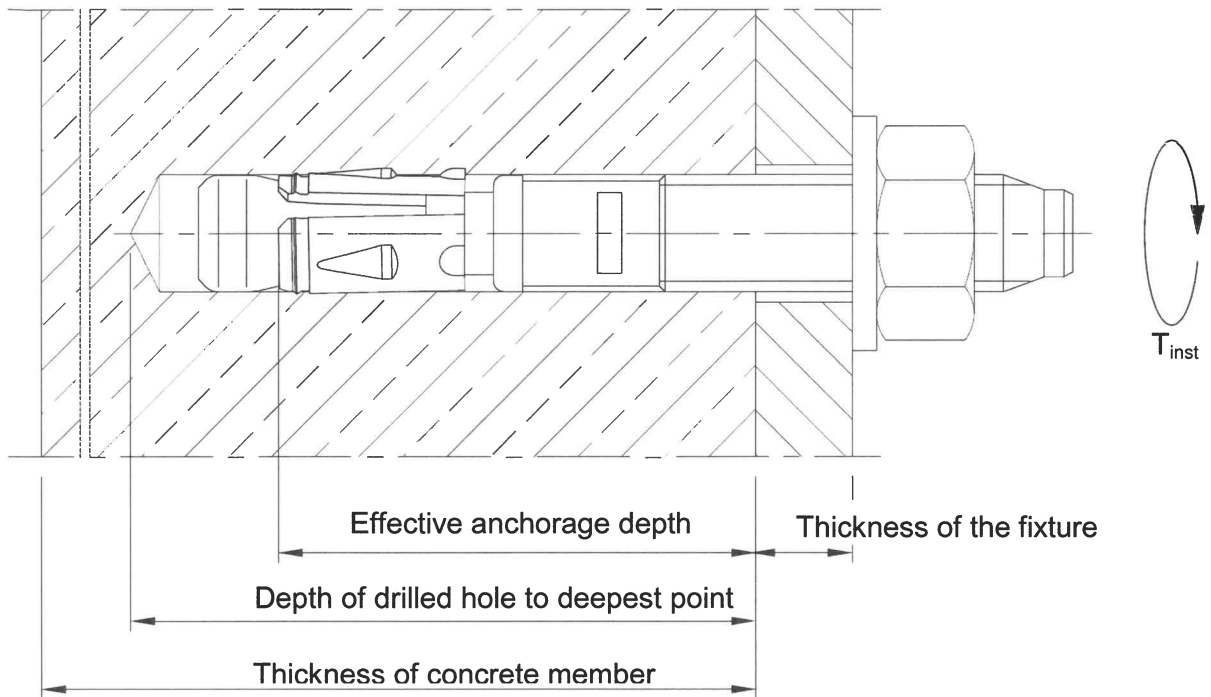

**Sormat through bolts S-KA+, S-KAK+, S-KAH+, S-KAH+ HCR /  
EJOT through bolts BA-V Plus, BA-F Plus, BA-E Plus, BA-E Plus HCR**

**Product description**  
Installation condition

**Annex A (2/3)**

## SORMAT through bolt

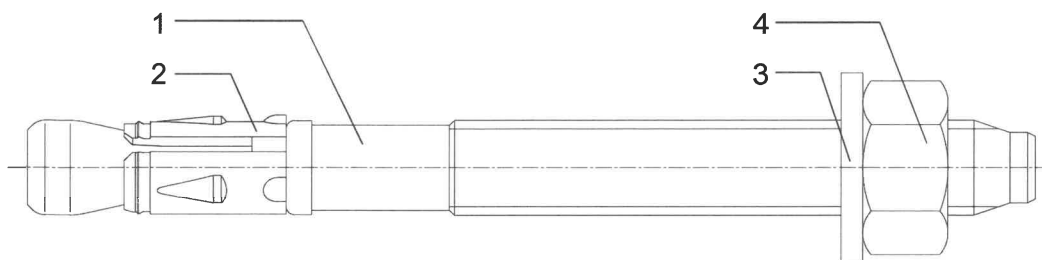

**Table A1: Materials for S-KA+ / BA-V Plus and S-KAK+ / BA-F Plus**

Part	Designation	Material <sup>1) 2)</sup>
1	Bolt	Cold forged carbon steel, EN 10263-2
2	Sleeve	Cold rolled galvanized steel strip, EN 10346 or stainless strip, EN 10088-2
3	Washer	Steel, DIN 125 (EN ISO 7089), DIN 440 (EN ISO 7094), DIN 9021 (EN ISO 7093)
4	Hexagonal nut	Steel, electroplated, property class 8, DIN 934 (EN ISO 4032)

<sup>1)</sup> **S-KA+ / BA-V Plus:** Parts 1,3 and 4 are zinc electroplated according to EN ISO 4042  $\geq 5\mu\text{m}$  and bright passivated

<sup>2)</sup> **S-KAK+ / BA-F Plus:** Parts 1,3 and 4 are hot dip galvanized according to EN ISO 10684  $\geq 50\mu\text{m}$

**Table A2: Materials for S-KAH+ / BA-E Plus**

Part	Designation	Material
1	Bolt	Cold forged stainless steel, EN 10088-3
2	Sleeve	Stainless steel strip, EN 10088-2
3	Washer	Stainless steel, DIN 125 (EN ISO 7089), DIN 440 (EN ISO 7094), DIN 9021 (EN ISO 7093)
4	Hexagonal nut	Stainless steel, property class 80, DIN 934 (EN ISO 4032)

**Table A3: Materials for S-KAH+ HCR / BA-E Plus HCR**

Part	Designation	Material
1	Bolt	Cold forged stainless steel, EN 10088-3 1.4529/1.4565
2	Sleeve	Stainless steel strip, EN 10088-2
3	Washer	Stainless steel, W 1.4529 / 1.4565, DIN 125 (EN ISO 7089), DIN 440 (EN ISO 7094), DIN 9021 (EN ISO 7093)
4	Hexagonal nut	Stainless steel, property class 70, W 1.4529 / 1.4565, DIN 934 (EN ISO 4032)

**Sormat through bolts S-KA+, S-KAK+, S-KAH+, S-KAH+ HCR /  
EJOT through bolts BA-V Plus, BA-F Plus, BA-E Plus, BA-E Plus HCR**

**Product description**  
Materials

Annex A (3/3)

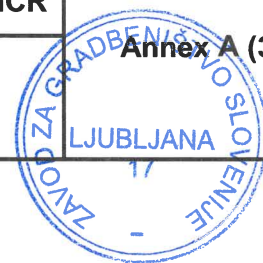

## Specifications of intended use

### Anchorage subjected to:

- Static, quasi static and seismic load,
- fire exposure.

### Base materials:

- Cracked and non-cracked concrete.
- Reinforced and unreinforced normal weight concrete of strength class C20/25 at minimum and C50/60 at maximum according to EN 206:2013+A1:2016.

### Use conditions (Environmental conditions):

- The S-KA+ / BA-V Plus and S-KAK+ / BA-F Plus anchors may be used in concrete subject to dry internal conditions.
- The S-KAH+ / BA-E Plus anchors may be used in concrete subject to dry internal conditions and also in concrete subject to external atmospheric exposure (including industrial and marine environment), or exposure in permanently damp internal conditions, if no particular aggressive conditions exist.
- The S-KAH+ HCR / BA-E Plus HCR anchors may be used in concrete subject to dry internal conditions and also in concrete subject to external atmospheric exposure, in permanently damp internal conditions or in other particular aggressive conditions.

*Note: Particular aggressive conditions are e.g. permanent, alternating immersion in seawater or the splash zone of seawater, chloride atmosphere of indoor swimming pools or atmosphere with extreme chemical pollution (e.g. desulphurization plants or road tunnels where de-icing materials are used).*

### Design:

- Anchorages are designed under the responsibility of an engineer experienced in anchorages and concrete work.
- Anchorages under static and quasi-static actions are designed in accordance with EOTA TR 055, Edition December 2016 or EN 1992-4:2018.
- For seismic application the anchorages are designed in accordance with EOTA TR 045 "Design of metal anchors for use in concrete under seismic actions".
- For application with resistance under fire exposure the anchorages are designed in accordance with the method given in EOTA TR 020, Edition May 2004.
- Verifiable calculation notes and drawings are prepared taking into account of the load to be anchored. The position of the anchor is indicated on the design drawings (e.g. position of the anchor relative to reinforcement or to supports, etc.).

### Installation:

- Anchor installation carried out by appropriately qualified personnel and under the supervision of the person responsible for technical matters on the site.
- Use of the anchor only as supplied by the manufacturer without exchanging the components of an anchor.
- Anchor installation in accordance with the manufacturer's specifications and drawings using the appropriate tools.
- Checks before placing the anchor to ensure that the strength class of the concrete in which the anchor is to be placed is in the range given and is not lower than that of the concrete to which the characteristic loads apply for.
- Check of concrete being well compacted, e.g. without significant voids.
- Cleaning of the hole of drilling dust.
- Anchor installation ensuring the specified embedment depth.
- Keeping of the edge distance and spacing to the specified values without minus tolerances.
- In case of aborted hole, drilling of new hole at a minimum distance of twice the depth of the aborted hole, or smaller distance provided the aborted drill hole is filled with high strength non-shrinkage mortar. No shear or oblique tension loads are allowed in the direction of a not filled aborted hole.
- Application of the torque moment given in Annex B2 using a calibrated torque wrench.

**Sormat through bolts S-KA+, S-KAK+, S-KAH+, S-KAH+ HCR /  
EJOT through bolts BA-V Plus, BA-F Plus, BA-E Plus, BA-E Plus HCR**

**Intended use  
Specifications**

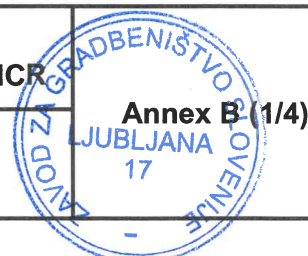

## SORMAT through bolt

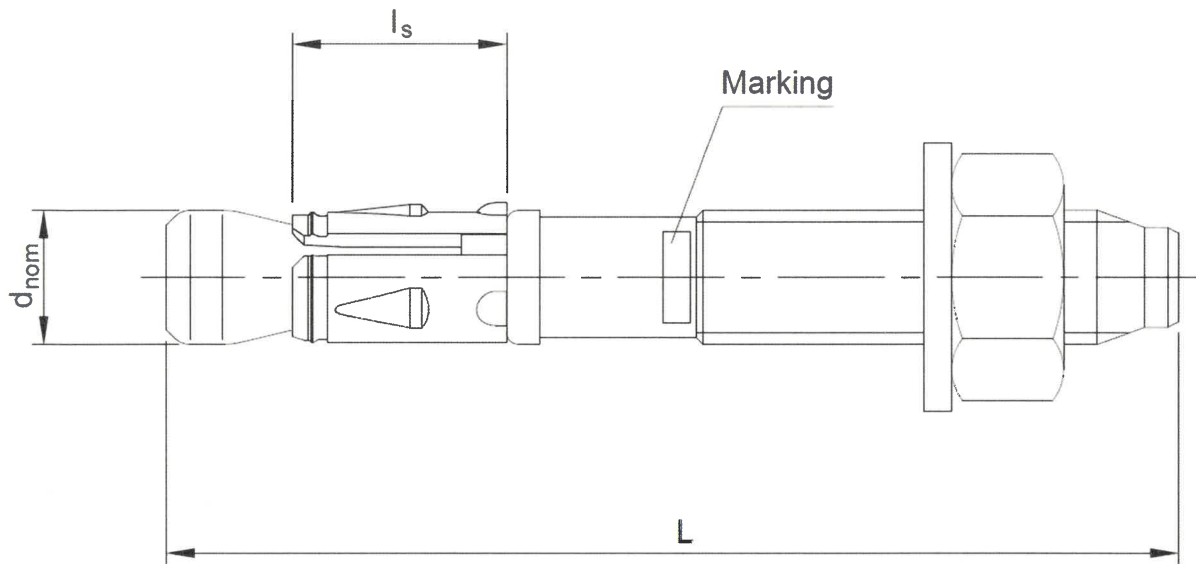

**Table B1:** Dimension of an anchor

Size	Nominal diameter $d_{nom}$ [mm]	Sleeve length $l_s$ [mm]	Total length L [mm]
M8	8	14,8	52 ... 420
M10	10	17,9	62 ... 420
M12	12	19,1	78 ... 420
M16	16	26,0	118 ... 420

Sormat through bolts S-KA+, S-KAK+, S-KAH+, S-KAH+ HCR /  
EJOT through bolts BA-V Plus, BA-F Plus, BA-E Plus, BA-E Plus HCR

**Intended use**  
Anchor dimensions

Annex B (2/4)

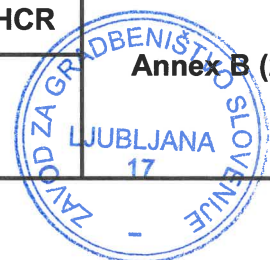



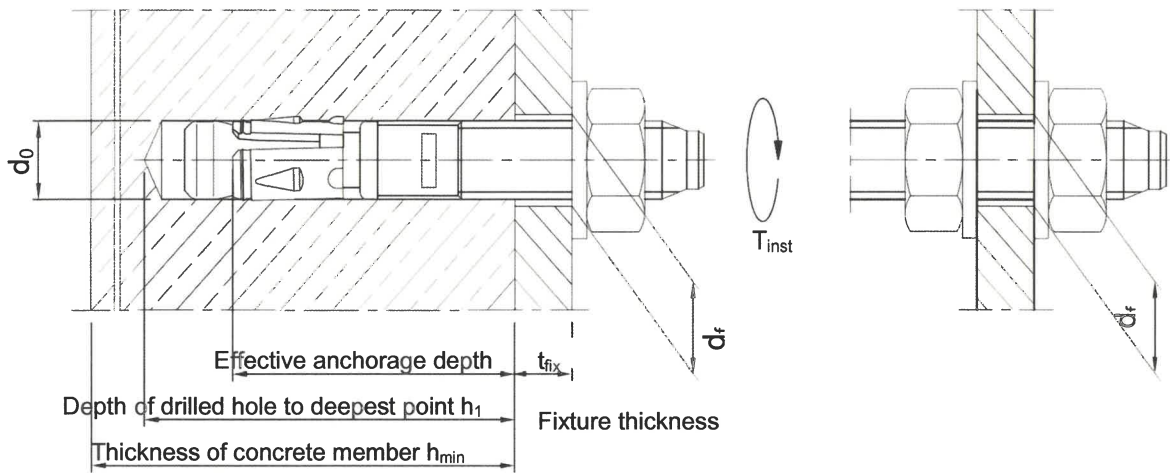
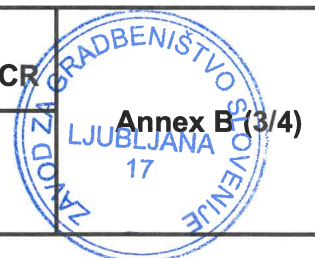

**Table B2:** Installation data

Sormat through bolts S-KA+, S-KAK+, S-KAH+, S-KAH+ HCR / EJOT through bolts BA-V Plus, BA-F Plus, BA-E Plus, BA-E Plus HCR		Anchor size						
		M8-1	M8-2	M10-1	M10-2	M12-1	M12-2	M16
Drill hole diameter	$d_0$ [mm]	8		10		12		16
Cutting diameter at the upper tolerance limit (maximum diameter bit)	$d_{cut,max} \leq$ [mm]	8,45		10,45		12,50		16,50
Depth of drilled hole to deepest point	$h_1 \geq$ [mm]	47	60	55	75	70	90	110
Effective anchorage depth	$h_{ef}$ [mm]	35	48	40	60	50	70	85
Diameter of clearance hole in the fixture	$d_f \leq$ [mm]	9		12		14		18
Thickness of the fixture	$t_{fix,max}$ [mm]	371	358	358	338	342	322	302
Required torque S-KA+ / BA-V Plus, S-KAK+ / BA-F Plus	$T_{inst}$ [Nm]	15		30		60		110
S-KAH+ / BA-E Plus, S-KAH+ HCR / BA-E Plus HCR		20		45		60		110

**Sormat through bolts S-KA+, S-KAK+, S-KAH+, S-KAH+ HCR /  
EJOT through bolts BA-V Plus, BA-F Plus, BA-E Plus, BA-E Plus HCR**

**Intended use  
Installation data**



**Table B3:** Minimum thickness of concrete member, spacing and edge distance

Sormat through bolts S-KA+, S-KAK+, S-KAH+, S-KAH+ HCR / EJOT through bolts BA-V Plus, BA-F Plus, BA-E Plus, BA-E Plus HCR		Anchor size						
		M8-1	M8-2	M10-1	M10-2	M12-1	M12-2	M16
Minimum thickness of concrete member	$h_{min}$ [mm]	80	100	100	120	100	140	170
	$h_{min-red}$ [mm]	/	80	/	100	/	/	/
Minimum spacing for $h_{min}$	$s_{min}$ [mm]	55	35	50	40	55	60	65
	$c \geq$ [mm]	75	50	95	60	110	70	95
Minimum edge distance for $h_{min}$	$c_{min}$ [mm]	40	40	50	50	60	55	65
	$s \geq$ [mm]	140	55	190	100	215	110	150
Minimum spacing for $h_{min-red}$	$s_{min}$ [mm]	/	35	/	40	/	/	/
	$c \geq$ [mm]	/	55	/	100	/	/	/
Minimum edge distance for $h_{min-red}$	$c_{min}$ [mm]	/	40	/	60	/	/	/
	$s \geq$ [mm]	/	60	/	90	/	/	/

Sormat through bolts S-KA+, S-KAK+, S-KAH+, S-KAH+ HCR /  
EJOT through bolts BA-V Plus, BA-F Plus, BA-E Plus, BA-E Plus HCR

Intended use  
Installation data

Annex B (4/4)

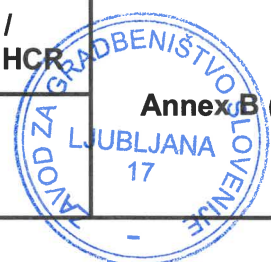

**Table C1:** Characteristic resistances under tension loads in case of static and quasi-static loading for design according EOTA TR 055 or **EN 1992-4:2018**

Sormat through bolts S-KA+, S-KAK+, S-KAH+, S-KAH+ HCR / EJOT through bolts BA-V Plus, BA-F Plus, BA-E Plus, BA-E Plus HCR				Anchor size						
				M8-1 <sup>1)</sup>	M8-2	M10-1	M10-2	M12-1	M12-2	M16
<b>Steel failure</b>										
Characteristic resistance	S-KA+ / BA-V Plus S-KAK+ / BA-F Plus	$N_{Rk,s}$	[kN]	15	15	26	26	39	39	73
	S-KAH+ / BA-E Plus S-KAH+ HCR / BA-E Plus HCR			15	15	26	26	40	40	73
Partial safety factor		$\gamma_{Ms}$ <sup>3)</sup>	[-]	1,4						
<b>Pull-out failure</b>										
Characteristic resistance in <b>cracked</b> concrete C20/25		$N_{Rk,p}$	[kN]	5	8,5	<sup>1)</sup>	12	<sup>2)</sup>	16	24
Characteristic resistance in <b>non-cracked</b> concrete C20/25		$N_{Rk,p}$	[kN]	8	11	12	19	<sup>2)</sup>	25	36
Increasing factor for $N_{Rk,p}$		$\psi_C$	C25/30	1,08	1,09	1,12	1,07	1,12	1,11	1,10
			C30/37	1,14	1,17	1,22	1,13	1,22	1,21	1,18
			C35/45	1,20	1,23	1,32	1,17	1,32	1,29	1,25
			C40/50	1,26	1,30	1,41	1,23	1,41	1,38	1,32
			C45/55	1,31	1,37	1,50	1,28	1,50	1,46	1,39
			C50/60	1,35	1,43	1,58	1,33	1,58	1,53	1,46
Partial safety factor		$\gamma_{inst}$ <sup>3)</sup>	[-]	1,0						
		$\gamma_{Mp}$ <sup>4)</sup>	[-]	1,5 <sup>4)</sup>						
<b>Concrete cone and splitting failure</b>										
Effective anchorage depth		$h_{ef}$	[mm]	35	48	40	60	50	70	85
Factor for cracked concrete		$k_{cr}$	[-]	7,7						
Factor for non-cracked concrete		$k_{ucr}$	[-]	11,0						
Spacing		$s_{cr,N}$	[mm]	106	144	120	180	150	210	254
Edge distance		$c_{cr,N}$	[mm]	53	72	60	90	75	105	127
Spacing ( splitting )		$s_{cr,sp}$	[mm]	170	192	160	240	200	280	340
Edge distance (splitting)		$c_{cr,sp}$	[mm]	85	96	80	120	100	140	170
Partial safety factor		$\gamma_{Msp}$ <sup>3)</sup>	[-]	1,5						

<sup>1)</sup> For use in dry internal exposure and for statically indeterminate structural components

<sup>2)</sup> Pull-out failure is not decisive

<sup>3)</sup> In absence of other national regulations

<sup>4)</sup> The installation safety factor of  $\gamma_{inst} = 1,0$  is included

**Sormat through bolts S-KA+, S-KAK+, S-KAH+, S-KAH+ HCR /  
EJOT through bolts BA-V Plus, BA-F Plus, BA-E Plus, BA-E Plus HCR**

**Performance**

Characteristic resistance under tension loads

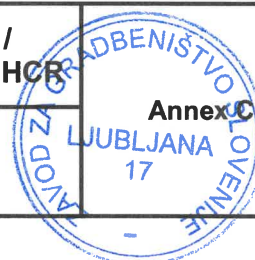

Annex C (1/7)

**Table C2:** Characteristic resistances under shear loads in case of static and quasi-static loading for design according to EOTA TR 055 or **EN 1992-4:2018**

Sormat through bolts S-KA+, S-KAK+, S-KAH+, S-KAH+ HCR / EJOT through bolts BA-V Plus, BA-F Plus, BA-E Plus, BA-E Plus HCR				Anchor size						
				M8-1 <sup>1)</sup>	M8-2	M10-1	M10-2	M12-1	M12-2	M16
<b>Steel failure without lever arm</b>										
Characteristic resistance	S-KA+ / BA-V Plus S-KAK+ / BA-F Plus	$V_{Rk,s}$	[kN]	12,6	12,6	20,4	20,4	30,0	30,0	54,1
	S-KAH+ / BA-E Plus S-KAH+ HCR / BA-E Plus HCR			15,8	15,8			34,4	34,4	68,6
Partial safety factor	$\gamma_{Ms}$ <sup>2)</sup>	[-]	1,25							
Factor for considering ductility	$k_7$	[-]	1,0							
<b>Steel failure with lever arm</b>										
Characteristic resistance	S-KA+ / BA-V Plus S-KAK+ / BA-F Plus	$M^0_{Rk,s}$	[Nm]	26,3	26,3	51	51	90	90	219,8
	S-KAH+ / BA-E Plus S-KAH+ HCR / BA-E Plus HCR			25,1	25,1					214,8
Partial safety factor	$\gamma_{Ms}$ <sup>2)</sup>	[-]	1,25							
<b>Concrete pryout failure</b>										
k-factor	$k_8$	[-]	2,21	1,94	3,31	3,31	2,84	2,84	2,71	
Partial safety factor	$\gamma_{Mc}$ <sup>2)</sup>	[-]	1,5							
<b>Concrete edge failure</b>										
Effective length of anchor under shear load	$l_f$	[mm]	35	48	40	60	50	70	85	
Outside diameter of anchor	$d_{nom}$	[mm]	8	8	10	12	16			
Partial safety factor	$\gamma_{Mc}$ <sup>2)</sup>	[-]	1,5							

<sup>1)</sup> For use in dry internal exposure and for statically indeterminate structural components

<sup>2)</sup> In absence of other national regulations

Sormat through bolts S-KA+, S-KAK+, S-KAH+, S-KAH+ HCR /  
EJOT through bolts BA-V Plus, BA-F Plus, BA-E Plus, BA-E Plus HCR

**Performance**

Characteristic resistance under shear loads



**Table C3:** Characteristic resistances under tension loads in case of fire exposure for design according to EOTA TR 020 or **EN 1992-4:2018**

Sormat through bolts S-KA+, S-KAK+, S-KAH+, S-KAH+ HCR / EJOT through bolts BA-V Plus, BA-F Plus, BA-E Plus, BA-E Plus HCR			Anchor size							
			M8-1 <sup>1)</sup>	M8-2	M10-1	M10-2	M12-1	M12-2	M16	
<b>Steel failure</b>										
Characteristic resistance $N_{Rk,fi}$	S-KA+ / BA-V Plus, S-KAK+ / BA-F Plus	R30	[kN]	1,31	1,31	2,09	2,09	3,05	3,05	5,69
		R60	[kN]	1,05	1,05	1,66	1,66	2,40	2,40	4,47
		R90	[kN]	0,80	0,80	1,24	1,24	1,74	1,74	3,25
		R120	[kN]	0,67	0,67	1,02	1,02	1,41	1,41	2,64
	S-KAH+ / BA-E Plus S-KAH+ HCR / BA-E Plus HCR	R30	[kN]	3,92	3,92	6,66	6,66	10,25	10,25	19,09
		R60	[kN]	2,70	2,70	4,59	4,59	7,07	7,07	13,16
		R90	[kN]	1,48	1,48	2,52	2,52	3,88	3,88	7,23
		R120	[kN]	0,87	0,87	1,48	1,48	2,29	2,29	4,26
<b>Pull-out failure</b>										
Characteristic resistance $N_{Rk,p,fi}$	R30	[kN]	1,25	2,13	<sup>2)</sup>	3,00	<sup>2)</sup>	4,00	6,00	
	R60	[kN]	1,25	2,13	<sup>2)</sup>	3,00	<sup>2)</sup>	4,00	6,00	
	R90	[kN]	1,25	2,13	<sup>2)</sup>	3,00	<sup>2)</sup>	4,00	6,00	
	R120	[kN]	1,00	1,70	<sup>2)</sup>	2,40	<sup>2)</sup>	3,20	4,80	
<b>Concrete cone and splitting failure<sup>3)</sup></b>										
Characteristic resistance $N_{Rk,c,fi}^0$	R30	[kN]	1,25	2,87	1,82	5,02	3,18	7,38	11,98	
	R60	[kN]	1,25	2,87	1,82	5,02	3,18	7,38	11,98	
	R90	[kN]	1,25	2,87	1,82	5,02	3,18	7,38	11,98	
	R120	[kN]	1,00	2,30	1,46	4,02	2,55	5,90	9,59	
Spacing	$s_{cr,N,fi}$	[mm]	4 x $h_{ef}$							
	$s_{min}$	[mm]	55	35	50	40	55	60	65	
Edge distance	$c_{cr,N,fi}$	[mm]	2 x $h_{ef}$							
	$c_{min}$	[mm]	Fire attack from one side: $c_{min} = 2 \times h_{ef}$ Fire attack from more than one side: $c_{min} \geq 300 \text{ mm and } \geq 2 \times h_{ef}$							

<sup>1)</sup> For use in dry internal exposure and for statically indeterminate structural components

<sup>2)</sup> Pull-out isn't decisive

<sup>3)</sup> As a rule, splitting failure can be neglected when cracked concrete and reinforcement is assumed

Design under fire exposure is performed according to the design method given in EOTA TR 020.

Under fire exposure usually cracked concrete is assumed. The design equations are given in EOTA TR 020 § 2.2.1.

In the absence of other national regulations the partial safety factor for resistance under fire exposure  $\gamma_{M,fi} = 1,0$  is recommended.

**Sormat through bolts S-KA+, S-KAK+, S-KAH+, S-KAH+ HCR /  
EJOT through bolts BA-V Plus, BA-F Plus, BA-E Plus, BA-E Plus HCR**

**Performance**

Characteristic tension resistance under fire exposure

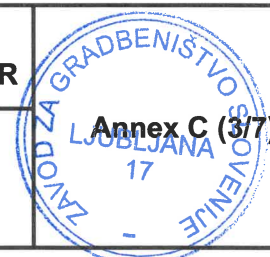

**Table C4:** Characteristic resistances under shear loads in case of fire exposure for design according to EOTA TR 020 or **EN 1992-4:2018**

Sormat through bolts S-KA+, S-KAK+, S-KAH+, S-KAH+ HCR / EJOT through bolts BA-V Plus, BA-F Plus, BA-E Plus, BA-E Plus HCR				Anchor size						
				M8-1 <sup>1)</sup>	M8-2	M10-1	M10-2	M12-1	M12-2	M16
<b>Steel failure without lever arm</b>										
Characteristic resistance $V_{Rk,s,fi}$	S-KA+ / BA-V Plus, S-KAK+ / BA-F Plus	R30	[kN]	1,31	1,31	2,09	2,09	3,05	3,05	5,69
		R60	[kN]	1,05	1,05	1,66	1,66	2,40	2,40	4,47
		R90	[kN]	0,80	0,80	1,24	1,24	1,74	1,74	3,25
		R120	[kN]	0,67	0,67	1,02	1,02	1,41	1,41	2,64
	S-KAH+ / BA-E Plus S-KAH+ HCR / BA-E Plus HCR	R30	[kN]	3,92	3,92	6,66	6,66	10,25	10,25	19,09
		R60	[kN]	2,70	2,70	4,59	4,59	7,07	7,07	13,16
		R90	[kN]	1,48	1,48	2,52	2,52	3,88	3,88	7,23
		R120	[kN]	0,87	0,87	1,48	1,48	2,29	2,29	4,26
<b>Steel failure with lever arm</b>										
Characteristic resistance $M_{Rk,s,fi}^0$	S-KA+ / BA-V Plus, S-KAK+ / BA-F Plus	R30	[Nm]	0,38	0,38	1,12	1,12	2,62	2,62	6,66
		R60	[Nm]	0,34	0,34	0,97	0,97	1,97	1,97	4,99
		R90	[Nm]	0,26	0,26	0,75	0,75	1,70	1,70	4,33
		R120	[Nm]	0,19	0,19	0,60	0,60	1,31	1,31	3,33
	S-KAH+ / BA-E Plus S-KAH+ HCR / BA-E Plus HCR	R30	[Nm]	0,75	0,75	1,87	1,87	3,93	3,93	9,99
		R60	[Nm]	0,60	0,60	1,50	1,50	3,28	3,28	8,32
		R90	[Nm]	0,45	0,45	1,20	1,20	2,62	2,62	6,66
		R120	[Nm]	0,38	0,38	1,05	1,05	2,10	2,10	5,33
<b>Concrete pryout failure</b>										
k-factor	$k_8$	[-]	2,21	1,94	3,31	3,31	2,84	2,84	2,71	
Characteristic resistance $V_{Rk,cp,fi}$	R30	[kN]	2,76	5,57	6,02	16,62	9,03	20,96	32,47	
	R60	[kN]	2,76	5,57	6,02	16,62	9,03	20,96	32,47	
	R90	[kN]	2,76	5,57	6,02	16,62	9,03	20,96	32,47	
	R120	[kN]	2,21	4,46	4,83	13,31	7,24	16,76	25,99	
<b>Concrete edge failure</b>										
The initial value $V_{Rk,c,fi}^0$ of the characteristic resistance in concrete C20/25 to C50/60 under fire exposure may be determined by:										
$V_{Rk,c,fi}^0 = 0,25 \times V_{Rk,c}^0 \quad (\leq R90) \qquad V_{Rk,c,fi}^0 = 0,20 \times V_{Rk,c}^0 \quad (R120)$										
with $V_{Rk,c}^0$ initial value of the characteristic resistance in cracked concrete C20/25 under normal temperature.										

<sup>1)</sup> For use in dry internal exposure and for statically indeterminate structural components

Design under fire exposure is performed according to the design method given in EOTA TR 020.

Under fire exposure usually cracked concrete is assumed. The design equations are given in EOTA TR 020 § 2.2.1.

EOTA TR 020 covers design for fire exposure from one side. For fire attack from more than one side the edge distance must be increased to  $c_{min} \geq 300$  mm and  $\geq 2 \times h_{ef}$ .

In the absence of other national regulations the partial safety factor for resistance under fire exposure  $\gamma_{M,fi} = 1,0$  is recommended.

**Sormat through bolts S-KA+, S-KAK+, S-KAH+, S-KAH+ HCR /  
EJOT through bolts BA-V Plus, BA-F Plus, BA-E Plus, BA-E Plus HCR**

**Performance**

Characteristic shear resistance under fire exposure



**Table C5:** Displacements under tension loads for static and quasi-static loading

<b>Sormat through bolts S-KA+, S-KAK+, S-KAH+, S-KAH+ HCR</b> / <b>EJOT through bolts BA-V Plus, BA-F Plus, BA-E Plus, BA-E Plus HCR</b>			Anchor size						
			M8-1 <sup>1)</sup>	M8-2	M10-1	M10-2	M12-1	M12-2	M16
Cracked C20/25 – C50/60	<b>N</b>	<b>[kN]</b>	<b>2,4</b>	<b>4,1</b>	<b>4,3</b>	<b>5,7</b>	<b>6,1</b>	<b>7,6</b>	<b>11,4</b>
	$\delta_{N0}$	[mm]	0,459	0,981	0,494	0,619	0,541	0,241	0,777
	$\delta_{N\infty}$	[mm]	0,653	1,470	0,976	1,367	0,981	1,263	2,211
Non-cracked C20/25 - C50/60	<b>N</b>	<b>[kN]</b>	<b>3,8</b>	<b>5,2</b>	<b>5,7</b>	<b>9,0</b>	<b>8,5</b>	<b>11,9</b>	<b>17,1</b>
	$\delta_{N0}$	[mm]	0,094	0,188	0,064	0,270	0,052	0,105	0,135
	$\delta_{N\infty}$	[mm]	0,653	1,470	0,976	1,367	0,981	1,263	2,211

**Table C6:** Displacements under shear loads for static and quasi-static loading

Cracked and non-cracked concrete C20/25 - C50/60			Anchor size						
			M8-1 <sup>1)</sup>	M8-2	M10-1	M10-2	M12-1	M12-2	M16
<b>S-KA+ / BA-V Plus, S-KAK+ / BA-F Plus</b>	<b>V</b>	<b>[kN]</b>	<b>7,2</b>	<b>7,2</b>	<b>10,5</b>	<b>10,5</b>	<b>16,4</b>	<b>16,4</b>	<b>30,9</b>
	$\delta_{V0}$	[mm]	1,090	1,090	1,943	0,680	2,438	2,127	2,778
	$\delta_{V\infty}$	[mm]	1,635	1,635	2,914	1,020	3,657	3,191	4,167
<b>S-KAH+ / BA-E Plus, S-KAH+ HCR / BA-E Plus HCR</b>	<b>V</b>	<b>[kN]</b>	<b>9,0</b>	<b>9,0</b>	<b>10,5</b>	<b>10,3</b>	<b>16,4</b>	<b>16,4</b>	<b>39,2</b>
	$\delta_{V0}$	[mm]	1,653	1,653	1,943	0,680	2,438	2,127	3,441
	$\delta_{V\infty}$	[mm]	2,480	2,480	2,914	1,020	3,657	3,191	5,162

<sup>1)</sup> For use in dry internal exposure and for statically indeterminate structural components

**Sormat through bolts S-KA+, S-KAK+, S-KAH+, S-KAH+ HCR / EJOT through bolts BA-V Plus, BA-F Plus, BA-E Plus, BA-E Plus HCR**

**Performance**

Displacements under tension and shear loads

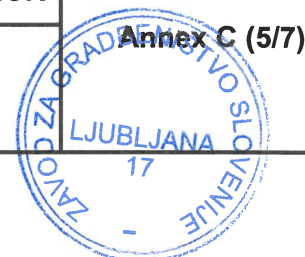

**Table C7:** Characteristic resistances in case of seismic action for design acc. EOTA TR 045: Performance Category C1 and C2

Sormat through bolts S-KA+, S-KAH+, S-KAH+ HCR / EJOT through bolts BA-V Plus, BA-E Plus, BA-E Plus HCR				Anchor size			
				M8-2	M10-2	M12-2	M16
<b>Tension - steel failure</b>							
Characteristic resistance C1		$N_{Rk,s,seis,C1}$	[kN]	15,0	-	-	-
Characteristic resistance C2	S-KA+ / BA-V Plus	$N_{Rk,s,seis,C2}$	[kN]	15,0	26,0	39,0	73,0
	S-KAH+ / BA-E Plus S-KAH+ HCR / BA-E Plus HCR	$N_{Rk,s,seis,C2}$	[kN]	15,0	26,0	40,0	73,0
Partial safety factor		$\gamma_{Ms,seis}^{1)}$	[-]	1,4			
<b>Tension - pull-out failure</b>							
Characteristic resistance C1	S-KA+ / BA-V Plus	$N_{Rk,p,seis,C1}$	[kN]	8,5	-	-	-
	S-KAH+ / BA-E Plus S-KAH+ HCR / BA-E Plus HCR	$N_{Rk,p,seis,C1}$	[kN]	8,4	-	-	-
Characteristic resistance C2	S-KA+ / BA-V Plus	$N_{Rk,p,seis,C2}$	[kN]	1,7	2,7	2,8	10,2
	S-KAH+ / BA-E Plus S-KAH+ HCR / BA-E Plus HCR	$N_{Rk,p,seis,C2}$	[kN]	3,6	3,2	3,3	11,1
Partial safety factor		$\gamma_{Mp,seis}^{1)}$	[-]	1,5 <sup>2)</sup>			
<b>Concrete cone and splitting failure<sup>3)</sup></b>							
Effective anchorage depth		$h_{ef}$	[mm]	48	60	70	85
Partial safety factor		$\gamma_{Mc,seis}^{1)}$ $\gamma_{Msp,seis}^{1)}$	[-]	1,5 <sup>2)</sup>			
<b>Shear - steel failure without lever arm</b>							
Characteristic resistance C1	S-KA+ / BA-V Plus	$V_{Rk,s,seis,C1}$	[kN]	8,1	-	-	-
	S-KAH+ / BA-E Plus S-KAH+ HCR / BA-E Plus HCR	$V_{Rk,s,seis,C1}$	[kN]	7,9	-	-	-
Characteristic resistance C2	S-KA+ / BA-V Plus	$V_{Rk,s,seis,C2}$	[kN]	9,5	8,5	13,8	30,7
	S-KAH+ / BA-E Plus S-KAH+ HCR / BA-E Plus HCR	$V_{Rk,s,seis,C2}$	[kN]	8,4	9,4	14,4	30,8
Partial safety factor		$\gamma_{Ms,seis}^{1)}$	[-]	1,25			
<b>Concrete pryout and concrete edge failure<sup>3)</sup></b>							
Effective anchorage depth		$h_{ef}$	[mm]	48	60	70	85
Partial safety factor		$\gamma_{Mc,seis}^{1)}$	[-]	1,5 <sup>2)</sup>			

<sup>1)</sup> In absence of other national regulations

<sup>2)</sup> The installation safety factor of  $\gamma_2 = 1,0$  is included

<sup>3)</sup> For concrete cone, splitting, pryout and edge failure, see EOTA TR 045

**Sormat through bolts S-KA+, S-KAK+, S-KAH+, S-KAH+ HCR /  
EJOT through bolts BA-V Plus, BA-F Plus, BA-E Plus, BA-E Plus HCR**

**Performance**

Characteristic resistances under seismic action  
Performance category C1 and C2

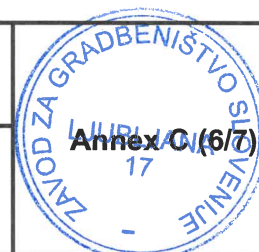



**Table C8:** Displacements in case of seismic action for design acc. EOTA TR 045: Performance Category C2

Sormat through bolts S-KA+, S-KAH+, S-KAH+ HCR / EJOT through bolts BA-V Plus, BA-E Plus, BA-E Plus HCR				Anchor size			
				M8-2	M10-2	M12-2	M16
Displacement under tension loads							
Displacement <b>DLS</b>	S-KA+ / BA-V Plus	$\bar{d}_{N,seis}$	[mm]	4,6	3,1	5,6	4,0
	S-KAH+ / BA-E Plus, S-KAH+ HCR / BA-E Plus HCR	$\bar{d}_{N,seis}$	[mm]	3,8	2,8	6,0	4,7
Displacement <b>ULS</b>	S-KA+ / BA-V Plus	$\bar{d}_{N,seis}$	[mm]	11,5	10,7	16,7	14,0
	S-KAH+ / BA-E Plus, S-KAH+ HCR / BA-E Plus HCR	$\bar{d}_{N,seis}$	[mm]	11,1	6,8	15,5	15,1
Displacement under shear loads							
Displacement <b>DLS</b>	S-KA+ / BA-V Plus	$\bar{d}_{V,seis}$	[mm]	2,7	3,9	3,6	3,7
	S-KAH+ / BA-E Plus, S-KAH+ HCR / BA-E Plus HCR	$\bar{d}_{V,seis}$	[mm]	2,7	4,5	4,7	3,9
Displacement <b>ULS</b>	S-KA+ / BA-V Plus	$\bar{d}_{V,seis}$	[mm]	4,7	5,8	5,3	6,8
	S-KAH+ / BA-E Plus, S-KAH+ HCR / BA-E Plus HCR	$\bar{d}_{V,seis}$	[mm]	4,8	7,6	7,5	7,7

Sormat through bolts S-KA+, S-KAK+, S-KAH+, S-KAH+ HCR /  
EJOT through bolts BA-V Plus, BA-F Plus, BA-E Plus, BA-E Plus HCR

**Performance**

Displacements under seismic action  
Performance category C2

Annex C (7/7)

